













CSS

Connective Systems & Supply

ROOFING SCREW CATALOG

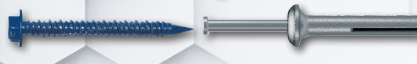

Table of Contents

	Wood-Grip Screws	Page 2
	Zip Screws	Page 5
	Self-Drill Screws	Page 6
	Pancake & Modified Truss Screws	Page 12
	Concealers	Page 14
	Quick Drive® Screws	Page 15
	Deck Screws	Page 18
	Rivets	Page 19
	Anchors	Page 20
	OMG Roofing Products	Page 21
	Trufast Fasteners	Page 22
	Roofing Nails, Plastic Caps & Staples	Page 26
	Dektite® Pipe Flashings	Page 28

Loveland 970.663.0304



Denver 970.829.6473

Wood-Grip Screws



TRUGRIP™ Metal-to-Wood Fasteners

Metal to wood applications

Recommended Driver
1/4" Magnetic Nut Driver



All In-Stock

Part No.	Description	Box Qty.
TRUGRIP™ Metal-to-Wood Fastener w/ Neo Washer		
1272000	9-15 x 1-1/2" TRUGRIP™ Metal-to-Wood Fastener w/ Neo Washer	4,000
TRUGRIP™ Metal-to-Wood Fastener w/ 1/2" Bonded Washer		
1262053	9-15 x 1" TRUGRIP™ Metal-to-Wood Fastener w/ 1/2" Bonded Washer	4,000
1264053	9-15 x 1-1/2" TRUGRIP™ Metal-to-Wood Fastener w/ 1/2" Bonded Washer	2,500
1267053	9-15 x 2" TRUGRIP™ Metal-to-Wood Fastener w/ 1/2" Bonded Washer	2,000
1268053	9-15 x 2-1/2" TRUGRIP™ Metal-to-Wood Fastener w/ 1/2" Bonded Washer	1,500
1269053	9-15 x 3" TRUGRIP™ Metal-to-Wood Fastener w/ 1/2" Bonded Washer	1,000



T17 WOOD-X™

- Miami Dade County Approved!
- H-LOW™ threads for Speed of Installation!
- T17 Cut point developed for High Performance!
- Engineered head flute resists High Torque Environments!
- Innovative L3 Dura Protec™ Coating to prevent Red Rust!
- EPDM washer for a Positive Seal!



410 WOOD-X™ Stainless

Part No.	Description	Box Qty.
#10 300 WOOD-X™ Stainless Steel Screw		
1010250--300S	#10 x 1" Wood-X Stainless Screw	3,000
1015250--300S	#10 x 1-1/2" Wood-X Stainless Screw	2,000
1020250--300S	#10 x 2" Wood-X Stainless Screw	In-Stock 2,000
1025250--300S	#10 x 2-1/2" Wood-X Stainless Screw	In-Stock 1,500
1030250--300S	#10 x 3" Wood-X Stainless Screw	1,000
1040250--300S	#10 x 4" Wood-X Stainless Screw	1,000

All In-Stock

Part No.	Description	Box Qty.
#10 T17 WOOD-X™ w/ Neo Washer (Woodgrip)		
1010250EWLPSG	#10 x 1" Wood-X w/ Neo Washer (Woodgrip)	3,000
1015250EWLPSG	#10 x 1-1/2" Wood-X w/ Neo Washer (Woodgrip)	2,500
1020250EWLPSG	#10 x 2" Wood-X w/ Neo Washer (Woodgrip)	2,000
1025250EWLPSG	#10 x 2-1/2" Wood-X w/ Neo Washer (Woodgrip)	1,500
1030250EWLPSG	#10 x 3" Wood-X w/ Neo Washer (Woodgrip)	1,000
1040250EWLPSG	#10 x 4" Wood-X w/ Neo Washer (Woodgrip)	1,000

Recommended Driver
5/16" Magnetic Nut Driver



Part No.	Description	Box Qty.
#10 410 WOOD-X™ Stainless Steel Screw w/ Washer		
1010250EWLPSGSS	#10 x 1" Wood-X Stainless Screw w/ Washer	3,000
1015250EWLPSGSS	#10 x 1-1/2" Wood-X Stainless Screw w/ Washer	2,500
1020250EWLPSGSS	#10 x 2" Wood-X Stainless Screw w/ Washer	2,000
1025250EWLPSGSS	#10 x 2-1/2" Wood-X Stainless Screw w/ Washer	1,500
1030250EWLPSGSS	#10 x 3" Wood-X Stainless Screw w/ Washer	1,000
1040250EWLPSGSS	#10 x 4" Wood-X Stainless Screw w/ Washer	1,000

In-Stock

Color options available. (See Chart)



T17 MASTERGRIP™

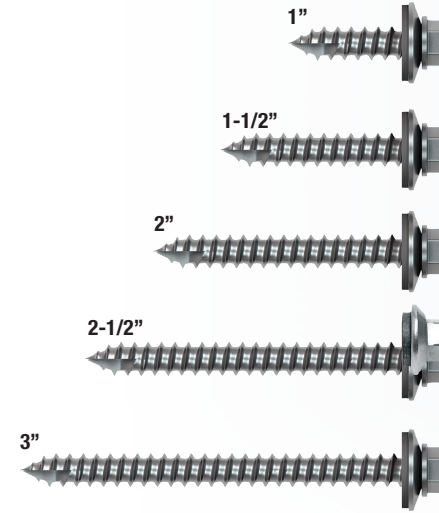

Recommended Driver
3/8" Magnetic Nutsetter



Color options available. (See Chart)

Part No.	Description	Box Qty.
#14 T17 MASTERGRIP™ Screw w/ Neo Washer Type 17 Point		
1410250EW3LPSPG	#14 x 1" T17 MASTERGRIP™ Screw w/ Neo Washer Type 17 Point	2,500
1415250EW3LPSPG	#14 x 1-1/2" T17 MASTERGRIP™ Screw w/ Neo Washer Type 17 Point	2,000
1420250EW3LPSPG	#14 x 2" T17 MASTERGRIP™ Screw w/ Neo Washer Type 17 Point	1,500
1425250EW3LPSPG	#14 x 2-1/2" T17 MASTERGRIP™ Screw w/ Neo Washer Type 17 Point	1,000
1430250EW3LPSPG	#14 x 3" T17 MASTERGRIP™ Screw w/ Neo Washer Type 17 Point	1,000



300 MASTERGRIP™ Stainless

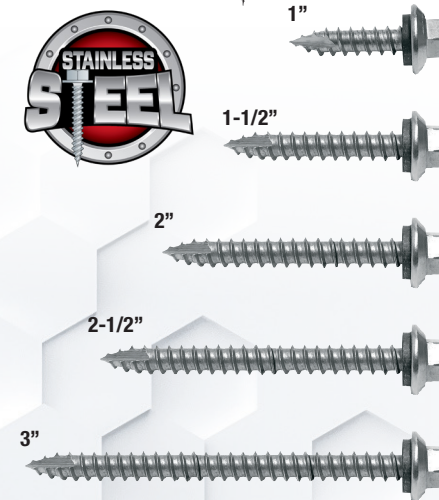

Recommended Driver
3/8" Magnetic Nutsetter



Color options available. (See Chart)

Part No.	Description	Box Qty.
#14 300 MASTERGRIP™ Stainless Steel Screw Type 17 Point		
1410250EW3LPSPGSS	#14 x 1" 300 MASTERGRIP™ Stainless Steel Screw Type 17 Point	2,500
1415250EW3LPSPGSS	#14 x 1-1/2" 300 MASTERGRIP™ Stainless Steel Screw Type 17 Point	2,000
1420250EW3LPSPGSS	#14 x 2" 300 MASTERGRIP™ Stainless Steel Screw Type 17 Point	2,000
1425250EW3LPSPGSS	#14 x 2-1/2" 300 MASTERGRIP™ Stainless Steel Screw Type 17 Point	2,000
1430250EW3LPSPGSS	#14 x 3" 300 MASTERGRIP™ Stainless Steel Screw Type 17 Point	1,500



T17 FASTLOK™

- T17 cut point for quick Panel Penetration!
- Engineered thread design to lock Panels In-Place!
- T17 FASTLOK™ for Speed of Installation!

Recommended Driver
5/16" Magnetic Nutsetter



Color options available. (See Chart)

Part No.	Description	Box Qty.
#12 T17 FASTLOK™ Screw w/ Neo Washer Type 17 Point		
1234250EW2LPSPG	1/4" HWH #12 x 3/4" T17 FASTLOK™ Screw w/ Neo Washer Type 17 Point	3,000
1215250EW2LPSPG	1/4" HWH #12 x 1-1/2" T17 FASTLOK™ Screw w/ Neo Washer Type 17 Point	2,000
N1234250EW2LPSPG	5/16" HWH #12 x 3/4" T17 FASTLOK™ Screw w/ Neo Washer Type 17 Point	3,000

In-Stock

- EPDM washer for Positive Seal!
- Innovative L3 Dura Protec™ coating Prevent Red Rust!

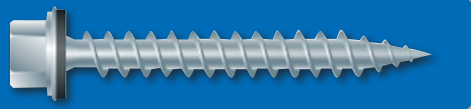

LAKESIDE
CONSTRUCTION FASTENERS

ZMAX™
"THE LONG LIFE FASTENER"

ZMAX™

Color options available. (See Chart)

Recommended Driver

5/16" Magnetic Nut Driver



Part No.	Description	Box Qty.
#10 ZMAX™ Alloy Head Fasteners Type 17 Point		
ZA1010250MX	#10 x 1" ZMAX™ Alloy Head Fasteners Type 17 Point	2,500
ZA1015250MX	#10 x 1-1/2" ZMAX™ Alloy Head Fasteners Type 17 Point	2,000
ZA1020250MX	#10 x 2" ZMAX™ Alloy Head Fasteners Type 17 Point	1,500
ZA1025250MX	#10 x 2-1/2" ZMAX™ Alloy Head Fasteners Type 17 Point	1,000
ZA1030250MX	#10 x 3" ZMAX™ Alloy Head Fasteners Type 17 Point	1,000

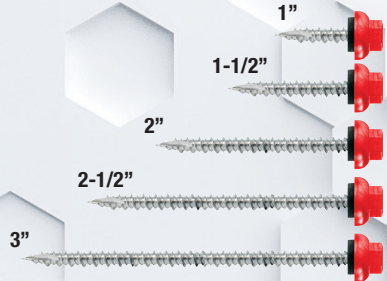

Color Options

WOOD-X™

MASTERGRIP™

FASTLOK™

ZMAX™

Z-STITCH™



Warm White	Snowdrift White	Sandstone	Parchment	Sierra Tan	Weathered Copper	Charcoal	Slate Gray	Terra Cotta	Colonial Red	Brandywine	River Teal
Mansard Brown	Dark Bronze	Ash Gray	Old Town Gray	Khaki	Med Bronze	Metallic Silver	Felt Green	Patriot Red	Copper Penny	Antique Patina	Tahoe Blue
Matte Black	Aged Copper	Patina Green	Hemlock Green	Classic Green	Old Zinc Gray	Ocean Blue	Regal Blue	Champagne Metallic	Mistique Plus	Copper Plated	Regal White

Zip Screws



Zip Screw



DESCRIPTION
#6 x 3/8" HWH Zip Screw (18000/box)
#7 x 1/2" HWH Zip Screw (15000/box)
#8 x 1/2" HWH Zip Screw (12000/box)



DESCRIPTION
#8 x 1/2" HWH Zip Screw Sharpie (15000/box)
#8 x 3/4" HWH Zip Screw Sharpie (10000/box)
#8 x 1" Slotted HWH Zip Screw (8000/box)
#8 x 1-1/2" HWH Zip Screw Sharpie (5000/box)

Recommended Driver

1/4" Magnetic Nut Driver



Lakeside Z-Stitch (Colored Zip Screws)



#8 x 1/2"
(500/bag | 5000/carton)

Recommended Driver

1/4" Magnetic Nut Driver



All In-Stock

DESCRIPTION
#8 x 1/2" HSWH Stitch Screw Dark Bronze
#8 x 1/2" HSWH Stitch Screw White
#8 x 1/2" HSWH Stitch Screw Hemlock Green
#8 x 1/2" HSWH Stitch Screw Matte Black
#8 x 1/2" HSWH Stitch Screw Mansard Brown
#8 x 1/2" HSWH Stitch Screw Medium Bronze
#8 x 1/2" HSWH Stitch Screw Slate Gray
#8 x 1/2" HSWH Stitch Screw Ash Gray
#8 x 1/2" HSWH Stitch Screw Sierra Tan
#8 x 1/2" HSWH Stitch Screw Regal White
#8 x 1/2" HSWH Stitch Screw Charcoal
#8 x 1/2" HSWH Stitch Screw Parchment
#8 x 1/2" HSWH Stitch Screw Sandstone
#8 x 1/2" HSWH Stitch Screw Medium Bronze

Color options available. (See Chart)

Self-Drill Screws

HWH TEK Screw | Zinc Coated

#8 HWH TEK2



Recommended Driver

1/4" Magnetic Nut Driver



PART NO.	SIZE	BOX QTY
HWD812	#8 x 1/2"	10M
HWD858	#8 x 5/8"	10M
HWD834	#8 x 3/4"	10M
HWD8100	#8 x 1"	8M
HWD8114	#8 x 1-1/4"	6M
HWD8112	#8 x 1-1/2"	4M
HWD8200	#8 x 2"	3M

#10 HWH TEK3



Recommended Driver

5/16" Magnetic Nutsetter



PART NO.	SIZE	BOX QTY
HWD1012	#10 x 1/2"	8M
HWD1058	#10 x 5/8"	7M
HWD1034	#10 x 3/4"	6M
HWD10100	#10 x 1"	5M
HWD10114	#10 x 1-1/4"	4M
HWD10112	#10 x 1-1/2"	3M
HWD10200	#10 x 2"	2M

#12 HWH TEK3



Recommended Driver

5/16" Magnetic Nutsetter



PART NO.	SIZE	BOX QTY
HWD12034	#12 x 3/4"	5M
HWD12100	#12 x 1"	3M
HWD12114	#12 x 1-1/4"	3M
HWD12112	#12 x 1-1/2"	3M
HWD12200	#12 x 2"	2M
HWD12212	#12 x 2-1/2"	1M
HWD12300	#12 x 3"	1M

Drill Point Options

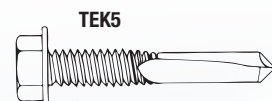
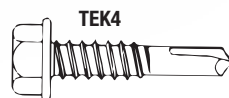
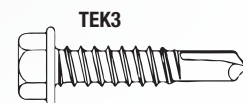
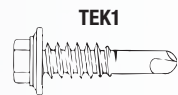

INTERCORP

HWH TEK Screw with Climate Coating

Available with washers



Recommended Driver

5/16" Magnetic Nutsetter

Available without washers

PART NO.	DESCRIPTION	BOX QTY
Intercorp H1032	#10 x 2" HWH Self-Drill TEK3	2,000
Intercorp H1048	#10 x 3" HWH Self-Drill TEK3	1,000
Intercorp H1212C	#12 x 3/4" HWH Self-Drill TEK3 Climate Coat	4,000
Intercorp H1216C	#12 x 1" HWH Self-Drill TEK3 Climate Coat (EDB761)	4,000
Intercorp H1220C	#12 x 1-1/4" HWH Self-Drill TEK3 Climate Coat (EDB782)	3,000
Intercorp H1224C	#12 x 1-1/2" HWH Self-Drill TEK3 Climate Coat (EDB801)	3,000
Intercorp H1424C	#12 x 1-1/2" HWH Self-Drill TEK3 Climate Coat (EDB961)	2,000
Intercorp H1232C	#12 x 2" HWH Self-Drill TEK3 Climate Coat (EDB821)	2,000
Intercorp H4C	#12-24 x 7/8" HWH Self-Drill TEK4 Climate Coat (EDC801)	4,000
Intercorp H5C	#12-24 x 1-1/4" HWH Self-Drill TEK5 Climate Coat (ECC720)	3,500
Intercorp H52C	#12-24 x 1-1/2" HWH Self-Drill TEK5 Climate Coat (ECC740)	2,500
Intercorp H53C	#12-24 x 2" HWH Self-Drill TEK5 Climate Coat (ECC750)	2,500
Intercorp HA1032	#10 x 2" HWH TEK3 w/ Neo Washer (/box)	1,500
Intercorp HA1212C	#12 x 3/4" HWH Self-Drill TEK3 w/ Neo Washer Climate Coat (EHL165)	3,000
Intercorp HA1216C	#12 x 1" HWH Self-Drill TEK3 w/ Neo Washer Climate Coat (EHL181)	3,000
Intercorp HA1220C	#12 x 1-1/4" HWH Self-Drill TEK3 w/ Neo Washer Climate Coat (EHL235)	2,500
Intercorp HA1224C	#12 x 1-1/2" HWH Self-Drill TEK3 w/ Neo Washer Climate Coat (EHL276)	2,000
Intercorp HA1232C	#12 x 2" HWH Self-Drill TEK3 w/ Neo Washer Climate Coat (EHL280)	1,500
Intercorp HA5C	#12-24 x 1-1/4" HWH Self-Drill TEK5 w/ Neo Washer Climate Coat (ECW725)	3,000
Intercorp HA52C	#12-24 x 1-1/2" HWH Self-Drill TEK5 w/ Neo Washer Climate Coat (ECW745)	2,500
Intercorp HA53C	#12-24 x 2" HWH Self-Drill TEK5 w/ Neo Washer Climate Coat (ECW755)	2,000



Drilit® Standard Drill Screws

Recommended Drivers

For #8
1/4" Magnetic Nut Driver

For #10 or #12
5/16" Magnetic Nut Driver

For #14 ONLY
1/4" Magnetic Nut Driver



Part No.	Description	Point Type	Finish	Box Qty
#8 Diameter, 1/4" Hex Washer Head				
EDA236-I	8-18 x 1/2"	#2 Drilit	Stalgard	10,000
EDA261-I	8-18 x 3/4"	#2 Drilit	Stalgard	8,000
EDA286-I	8-18 x 1"	#2 Drilit	Stalgard	5,000
#10 Diameter, 5/16" High Hex Washer Head				
EDB401	10-16 x 1/2"	#3 Drilit	Stalgard	5,000
EDB426	10-16 x 5/8"	#3 Drilit	Stalgard	6,000
EDB446	10-16 x 3/4"	#3 Drilit	Stalgard	6,000
EFC460-I	10-16 x 3/4"	#3 Drilit	Zinc	6,000
EDC450	10-16 x 3/4"	#1 Drilit	Stalgard	5,000
EDB486	10-16 x 1"	#3 Drilit	Stalgard	5,000
EDB541	10-16 x 1-1/2"	#3 Drilit	Stalgard	3,000
EDB571	10-16 x 2"	#3 Drilit	Stalgard	2,000
#12 Diameter, 5/16" Hex Washer Head				
EDC745	12-14 x 3/4"	#1 Drilit	Stalgard	5,000
EDB741	12-14 x 3/4"	#3 Drilit	Stalgard	5,000
EDB761	12-14 x 1"	#3 Drilit	Stalgard	4,000
EDB782	12-14 x 1-1/4"	#3 Drilit	Stalgard	3,000
EDB801	12-14 x 1-1/2"	#3 Drilit	Stalgard	2,500
EDB821	12-14 x 2"	#3 Drilit	Stalgard	2,000
EDB840	12-14 x 3"	#3 Drilit	Stalgard	1,000
EDB845	12-14 x 4"	#3 Drilit	Stalgard	500
1/4" Diameter, 3/8" Hex Washer Head				
EDB936	1/4-14 x 3/4"	#3 Drilit	Stalgard	3,500
EDC930	1/4-14 x 7/8"	#1 Drilit	Stalgard	4,000
EDB946	1/4-14 x 1"	#3 Drilit	Stalgard	3,000
EDB956	1/4-14 x 1-1/4"	#3 Drilit	Stalgard	2,000
EDB961	1/4-14 x 1-1/2"	#3 Drilit	Stalgard	2,000
EDB971	1/4-14 x 2"	#3 Drilit	Stalgard	1,500
EDB981	1/4-14 x 3"	#3 Drilit	Stalgard	800
EDB983	1/4-14 x 4"	#3 Drilit	Stalgard	500

Features & Benefits

- Eliminates separate drilling and tapping operations
- Fasteners coated with Stalgard finish typically show no red rust or other base metal corrosion on significant surfaces even after 1000 hours of 5% neutral salt spray exposure (per ASTM B117)



Drilit® Drill Screws with Bonded Sealing Washers

Recommended Drivers

For #10 or #12
5/16" Magnetic Nut Driver

For #14 ONLY
3/8" Magnetic Nut Driver



Part No.	Description	Point Type	Washer O.D.	Finish	Box Qty
#10 Diameter, 5/16" Hex Washer Head					
EHL111	10-16 x 3/4"	#3 Drilit	1/2"	Stalgard	4,000
EHL146	10-16 x 1-1/2"	#3 Drilit	1/2"	Stalgard	2,000
#12 Diameter, 5/16" Hex Washer Head					
EHL165	12-14 x 3/4"	#3 Drilit	9/16"	Stalgard	3,000
EHL351	12-24 x 7/8"	#4 Drilit	9/16"	Stalgard	2,500
EHL181	12-14 x 1"	#3 Drilit	9/16"	Stalgard	2,500
EHL235	12-14 x 1-1/4"	#3 Drilit	9/16"	Stalgard	2,000
EHL371	12-24 x 1-1/4"	#4.5 Drilit	9/16"	Stalgard	2,500
EHL276	12-14 x 1-1/2"	#3 Drilit	9/16"	Stalgard	2,000
EHL280	12-14 x 2"	#3 Drilit	9/16"	Stalgard	1,500
EHL295	12-14 x 3"	#3 Drilit	9/16"	Stalgard	1,000
EHL310	12-14 x 4"	#3 Drilit	9/16"	Stalgard	500
ECW725	12-24 x 1-1/4"	#5 Drilitite	9/16"	Stalgard	2,500
ECW745	12-24 x 1-1/2"	#5 Drilitite	9/16"	Stalgard	2,000
ECW755	12-24 x 2"	#5 Drilitite	9/16"	Stalgard	1,000
1/4" Diameter, 3/8" Hex Washer Head					
EHL515	1/4-14 x 3/4"	#3 Drilit	5/8"	Stalgard	2,500
EHL315	1/4-14 x 7/8"	#1 Drilit	9/16"	Stalgard	2,500
EHL530	1/4-14 x 1"	#3 Drilit	5/8"	Stalgard	2,000
EHL556	1/4-14 x 1-1/4"	#3 Drilit	5/8"	Stalgard	1,500
EHL577	1/4-14 x 1-1/2"	#3 Drilit	5/8"	Stalgard	1,500
EHL585	1/4-14 x 2"	#3 Drilit	5/8"	Stalgard	1,000
EHL600	1/4-14 x 3"	#3 Drilit	5/8"	Stalgard	800
EHL610	1/4-14 x 4"	#3 Drilit	5/8"	Stalgard	500

Features & Benefits

- EPDM washer material is UV- and heat-resistant for long-term protection against leakage
- Stalgard coating provides 1000 hours of salt spray resistance (per ASTM B117)

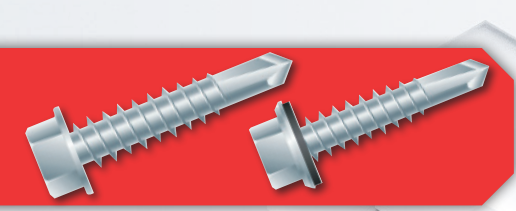

Dril-Flex® Structural Drill Screws

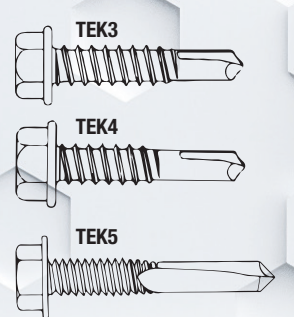

- Features & Benefits**
- Stalgard SUB coating (Hex washer product only) provides 2000 hours of salt spray resistance (per ASTM B117)
 - High-hardness points and lead threads for drilling and tapping with lower-hardness in load-bearing threads for ductility
 - Virtually immune to delayed embrittlement failures

Part No.	Description	Drill Pt.	Finish	Box Qty
#10 Diameter, 5/16" Hex Washer Head				
EAF430	10-16 x 3/4"	#3	Stalgard SUB	6,000
EAF460	10-16 x 1-1/2"	#3	Stalgard SUB	2,500
EAF470	10-16 x 2"	#3	Stalgard SUB	2,000
EAF480	10-16 x 2-1/2"	#3	Stalgard SUB	1,500
#12 Diameter, 5/16" Hex Washer Head				
EAF621*	12-14 x 7/8"	#3	Stalgard SUB	5,000
EAF641	12-14 x 1"	#3	Stalgard SUB	4,000
EAF681	12-14 x 1-1/2"	#3	Stalgard SUB	2,500
EAF690	12-14 x 2"	#3	Stalgard SUB	2,000
EAF715	12-14 x 3"	#2	Stalgard SUB	1,000
1/4" Diameter, 3/8" Hex Washer Head				
EAF816	1/4-14 x 1"	#3	Stalgard SUB	3,000
EAF841	1/4-14 x 1-1/2"	#3	Stalgard SUB	2,000
EAF876	1/4-20 x 1-1/2"	#4	Stalgard SUB	2,000
EAF846	1/4-14 x 2"	#3	Stalgard SUB	1,500
EAF886	1/4-20 x 2"	#4	Stalgard SUB	1,500
EAF865	1/4-20 x 1-1/8"	#4	Stalgard SUB	2,500
EAF888	1/4-20 x 1-3/4"	#5	Stalgard SUB	1,000
EAF890	1/4-20 x 2-1/2"	#4	Stalgard SUB	1,000
EAF900	1/4-20 x 3-3/8"	#4	Stalgard SUB	500
EAF910	1/4-20 x 4"	#4	Stalgard SUB	500

Recommended Drivers

For #8
1/4" Magnetic
Nut Driver



For #10 or #12
5/16" Magnetic
Nut Driver

For #14 ONLY
3/8" Magnetic
Nut Driver



410 Stainless Self-Drill HWH Screw

Metal to metal applications

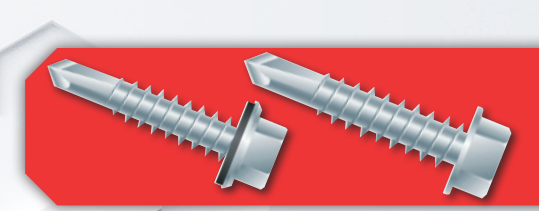

Part No.	Size	Drill Pt.	Box Qty.
410 Stainless Steel Self-Drilling Unslotted Indented Hex Washer Head			
4H808	8-18 x 1/2"	#2	5,000
4H812	8-18 x 3/4"	#2	5,000
4H816	8-18 x 1"	#2	4,000
4H1008	10-16 x 1/2"	#2	5,000
4H1012	10-16 x 3/4"	#3	4,000
4H1016	10-16 x 1"	#3	3,000
4H1020	10-16 x 1-1/4"	#3	2,500
4H1024	10-16 x 1-1/2"	#3	2,000
4H1032	10-16 x 2"	#3	1,500
4H1212	12-14 x 3/4"	#3	400
4H1216	12-14 x 1"	#3	3,000
4H1220	12-14 x 1-1/4"	#3	3,000
4H1224	12-14 x 1-1/2"	#3	2,500
4H1232	12-14 x 2"	#3	2,000
4H1240	12-14 x 2-1/2"	#3	1,000
4H1412	14-14 x 3/4"	#3	3,000
4H1416	14-14 x 1"	#3	2,500
4H1420	14-14 x 1-1/4"	#3	2,000
4H1424	14-14 x 1-1/2"	#3	1,500
4H1432	14-14 x 2"	#3	100
4H1440	14-14 x 2-1/2"	#3	800
4H1448	14-14 x 3"	#3	500
4H1464	14-14 x 4"	#3	500
4H1480	14-14 x 5"	#3	250
4H1496	14-14 x 6"	#3	250
4H1	14-14 x 7/8 #12 HD	#1	2,500



Bi-Flex® 300 Stainless Steel Bi-Metal Self-Drilling Fasteners

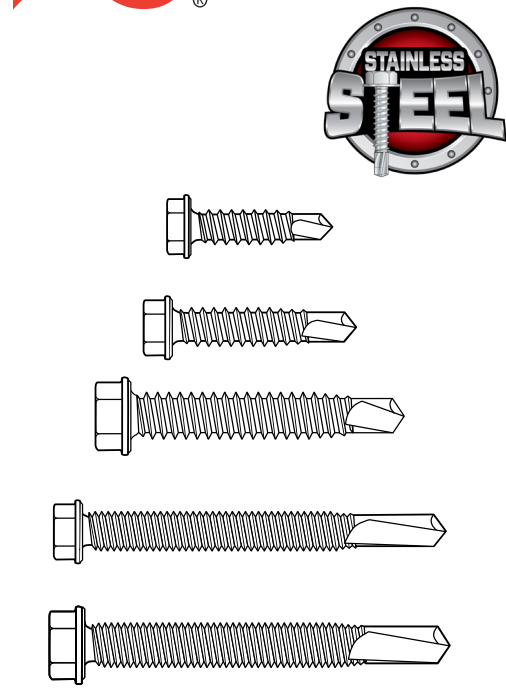

Part No.	Size	Drill Pt.	Box Qty.
300 Stainless Steel Bi-Metal Self-Drilling Fastener, 5/16" Hex Head			
EAJ110	10-16 x 3/4"	#2	5,000
EAJ140	10-16 x 1-1/2"	#2	2,500
EAJ185	12-14 x 1"	#2	3,000
EAJ215	12-14 x 1-1/2"	#2	2,500
EAJ240	12-14 x 2"	#2	1,500
EAJ190	12-14 x 1"	#3	4,000
EAJ220	12-14 x 1-1/2"	#3	2,500
EAJ260	12-14 x 2-1/2"	#3	1,000
EAJ340	12-14 x 2"	#5	2,000
300 Stainless Steel Bi-Metal Self-Drilling Fastener, 3/8" Hex Head			
EAJ415	1/4-14 x 1"	#2	2,500
EAJ430	1/4-14 x 1-1/2"	#2	1,000
EAJ445	1/4-14 x 2"	#2	1,500
EAJ540	1/4-20 x 1"	#3	2,500
EAJ580	1/4-20 x 1-1/2"	#3	1,000
EAJ610	1/4-20 x 2"	#3	1,500
EAJ640	1/4-20 x 2-1/2"	#3	1,000
EAJ650	1/4-20 x 3"	#3	500
EAJ660	1/4-20 x 4"	#3	500
EAJ615	1/4-20 x 2"	#5	1,500
EAJ690C	1/4-20 x 8"	#5	150



410 Stainless Self-Drill HWH Screw w/ Bonded NEO-EPDM Washer

Metal to metal applications



Part No.	Size	Drill Pt.	Box Qty.
410 SS Self-Drilling Unslotted Indented HWH w/Bonded NEO-EPDM Washer			
4HA808	8-18 x 1/2"	#2	5,000
4HA812	8-18 x 3/4"	#2	5,000
4HA816	8-18 x 1"	#2	4,000
4HA1012	10-16 x 3/4"	#3	4,000
4HA1016	10-16 x 1"	#3	3,000
4HA1020	10-16 x 1-1/4"	#3	2,500
4HA1024	10-16 x 1-1/2"	#3	2,000
4HA1032	10-16 x 2"	#3	1,500
4HA1212	12-14 x 3/4"	#3	3,000
4HA1216	12-14 x 1"	#3	3,000
4HA1220	12-14 x 1-1/4"	#3	2,500
4HA1224	12-14 x 1-1/2"	#3	2,500
4HA1232	12-14 x 2"	#3	1,500
4HA1240	12-14 x 2-1/2"	#3	1,000
4HA1412	14-14 x 3/4"	#3	3,000
4HA1416	14-14 x 1"	#3	2,500
4HA1420	14-14 x 1-1/4"	#3	2,000
4HA1424	14-14 x 1-1/2"	#3	1,500
4HA1432	14-14 x 2"	#3	1,000
4HA1440	14-14 x 2-1/2"	#3	800
4HA1448	14-14 x 3"	#3	500
4HA1464	14-14 x 4"	#3	500
4HA1480	14-14 x 5"	#3	250
4HA1	14-14 x 7/8 #12 HD	#1	2,500

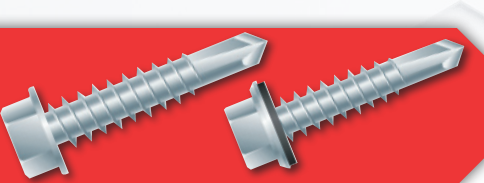

SFS intec — Impax™ Carbon Steel Self-Drill Fasteners

Metal to metal applications



10-16 SD3



12-14 SD3



1/4-14 SD3

Recommended Drivers

For #8
1/4" Magnetic
Nut Driver



For #10 or #12
5/16" Magnetic
Nut Driver

For #14 ONLY
3/8" Magnetic
Nut Driver

Part No.	Description	Drill Pt.	Box Qty
Impax HWH 1/4" AF, No Washer			
793029	8-18 x 1/2"	SD2	10,000
793080	8-18 x 5/8"	SD2	10,000
793138	8-18 x 3/4"	SD2	5,000
Impax HWH 5/16" AF, No Washer			
793249	10-16 x 5/8"	SD2	7,500
793362	10-16 x 3/4"	SD3	5,000
793413	10-16 x 1"	SD3	5,000
793469	10-16 x 1-1/4"	SD3	3,500
793496	10-16 x 1-1/2"	SD3	3,500
Impax HWH 5/16" AF, No Washer			
783060	12-14 x 3/4"	SD3	5,000
794234	12-14 x 1"	SD3	2,500
795053	12-14 x 1-1/4"	SD3	2,500
796234	12-14 x 1-1/2"	SD3	2,500
796909	12-14 x 2"	SD3	2,000
797000	12-14 x 2-1/2"	SD3	2,000
797067	12-14 x 3"	SD3	1,000
1299624	12-14 x 4"	SD3	1,000
797805	1/4-14 x 7/8" (lap)	SD1	2,500
Impax HWH 3/8" AF, No Washer			
797166	1/4-14 x 3/4"	SD3	2,500
798553	1/4-14 x 1"	SD3	2,500
798810	1/4-14 x 1-1/4"	SD3	2,000
798973	1/4-14 x 1-1/2"	SD3	2,000
799086	1/4-14 x 2"	SD3	1,500
1300360	1/4-14 x 2-1/2"	SD3	1,000
799115	1/4-14 x 3"	SD3	750
1300369	1/4-14 x 4"	SD3	1,000

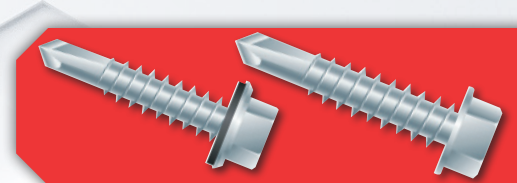

SFS intec — Impax™ Carbon Steel Self-Drill Fasteners with bondSeal Washer

Metal to metal applications



#10-16 SD3



#12-14 SD3



1/4-14 SD3



Part No.	Description	Drill Pt.	Carton Qty.
Impax HWH 5/16" AF, with bondSeal washer			
502820	10-16 x 5/8"	SD2	5,000
793256	10-16 x 3/4"	SD3	5,000
793373	10-16 x 1"	SD3	5,000
793461	10-16 x 1-1/4"	SD3	2,500
793475	10-16 x 1-1/2"	SD3	2,500
Impax HWH 5/16" AF, with bondSeal Washer			
1302885	12-14 x 3/4"	SD3	2,500
1303353	12-14 x 1"	SD3	2,500
1303633	12-14 x 1-1/4"	SD3	2,500
1303919	12-14 x 1-1/2"	SD3	2,000
1304186	12-14 x 2"	SD3	1,500
796942	12-14 x 2-1/2"	SD3	2,000

Item No.	Description	Drill Pt.	Box Qty.
Impax HWH 5/16" AF, with bondSeal Washer			
797019	12-14 x 3"	SD3	1,500
797074	12-14 x 4"	SD3	1,000
1304321	1/4-14 x 7/8" (lap)	SD1	2,500
Impax HWH 3/8" AF, with bondSeal Washer			
797143	1/4-14 x 3/4"	SD3	2,500
798515	1/4-14 x 1"	SD3	2,000
798777	1/4-14 x 1-1/4"	SD3	2,000
798957	1/4-14 x 1-1/2"	SD3	2,000
799066	1/4-14 x 2"	SD3	1,500
799092	1/4-14 x 2-1/2"	SD3	1,500
799104	1/4-14 x 3"	SD3	750
799119	1/4-14 x 4"	SD3	1,000

SFS intec — Impax™ Structural Steel Self-Drill Fasteners

Metal to metal applications



1/4-20 SD5



12-24 SD5



12-24 SD5



Part No.	Description	Drill Pt.	Carton Qty.
Impax HWH 5/16" AF, No Washer			
783082	12-24 x 7/8"	SD4	2,500
795664	12-24 x 1-1/4"	SD4.5	2,500
795839	12-24 x 1-1/4"	SD5	2,500
796618	12-24 x 1-1/2"	SD5	2,500
783126	12-24 x 2"	SD5	2,000
Impax HWH 3/8" AF, No Washer			
1356393	1/4-20 x 3"	SD5	1,500
1356395	1/4-20 x 4"	SD5	1,000
1356396	1/4-20 x 5"	SD5	600
1356398	1/4-20 x 6"	SD5	500
1356399	1/4-20 x 7"	SD5	500
1356400	1/4-20 x 8"	SD5	500

Item No.	Description	Drill Pt.	Bo Qty.
Impax HWH 5/16" AF, with bondSeal Washer			
783065	12-24 x 7/8"	SD4	2,500
795491	12-24 x 1-1/4"	SD4.5	2,500
795718	12-24 x 1-1/4"	SD5	2,500
796507	12-24 x 1-1/2"	SD5	2,000
783097	12-24 x 2"	SD5	2,000
Impax HWH 3/8" AF, with bondSeal Washer			
1356420	1/4-20 x 3"	SD5	1,500
1356421	1/4-20 x 4"	SD5	1,000
1356422	1/4-20 x 5"	SD5	750
1356423	1/4-20 x 6"	SD5	500
1356424	1/4-20 x 7"	SD5	500
1356425	1/4-20 x 8"	SD5	500

SFS intec — Color Options

Warm White	Snowdrift White	Sandstone	Parchment	Taupe	Weathered Copper	Mansard Brown
Dark Bronze	Ash Gray	Old Town Gray	Khaki	Med Bronze	Matte Black	Aged Copper
Patina Green	Hemlock Green	Classic Green	Old Zinc Gray	Charcoal	Slate Gray	Terra Cotta
Colonial Red	Brandywine	River Teal	Metallic Silver	Felt Green	Patriot Red	Copper Penny
Antique Patina	Tahoe Blue	Ocean Blue	Regal Blue	Champagne Metallic	Mistique Plus	Copper Plated

Modified Truss and Pancake Screws

Modified Truss Sharpie

Modified Truss Sharpie

All In-Stock

Part No.	Size	Box Qty
MT812	#8 x 1/2"	10M
MT834	#8 x 3/4"	8M
MT100	#8 x 1"	5M
MT114	#8 x 1-1/4"	5M
MT158	#8 x 1-5/8"	5M
MT178	#8 x 1-7/8"	4M
MT200	#8 x 2"	2.5M
MT212	#8 x 2-1/2"	2M
MT300	#8 x 3"	1.5M

Recommended Drivers

#2 Reduced x 1" Phillips Bit Tip

Modified Truss Self-Drill

All In-Stock

Part No.	Size	Box Qty
MTD812	#8 x 1/2"	10M
MTD834	#8 x 3/4"	10M
MTD100	#8 x 1"	8M
MTD114	#8 x 1-1/4"	6M
MTD158	#8 x 1-5/8"	5M
MTD178	#8 x 1-7/8"	3M
MTD200	#8 x 2"	2.5M
MTD212	#8 x 2-1/2"	2M
MTD300	#8 x 3"	1.5M
MTD1034	#10 x 3-4"	5M

#2 Reduced x 2" Bit Tip



INTERCORP Modified Truss Self-Drill | 410 Stainless Steel

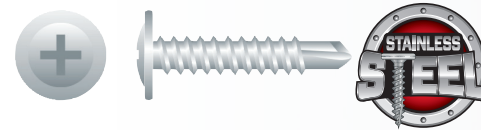

Part No.	Size	Pt	Bulk Qty
410 Stainless Steel Self-Drilling Phillips Modified Truss (R/W) Head, Passivated and Waxed			
4M82	#8-18 x 1/2"	2	5M
4M83	#8-18 x 3/4"	2	5M
4M84	#8-18 x 1"	2	4M
4M85	#8-18 x 1-1/4"	2	3M
4M87	#8-18 x 1-5/8"	2	3M

INTERCORP Modified Truss Sharpie | Type 17 | 305 Stainless Steel

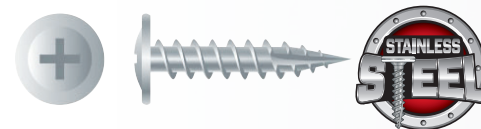

Recommended Drivers

#2 Reduced x 1" Phillips Bit Tip

#2 Reduced x 2" Bit Tip

Part No.	Size	Bulk Qty
305 Stainless Steel Phillips Modified Truss (R/W) Head, Type '17'		
X86MSS	#8 x 3/4"	5M
X88MSS	#8 x 1"	4M
X89MSS	#8 x 1-1/4"	3M
X90MSS	#8 x 1-5/8"	3M

Pancake & Ultra Low Profile Pancake Head Screws



SFS intec Clip Attachment Fasteners Standing Seam Panel Clip Attachment



Recommended Drivers



#2 Mod. Phillips Combo Driver

Part No.	Description	Drive Type	Drill Point	Carton Qty.
Metal to Wood Application				
1545869	10 x 1" Pancake	2/2 Square Phillips	Type A	5,000
1545862	10 x 1-1/2" Pancake	2/2 Square Phillips	Type A	2,500
1545882	10 x 2" Pancake	2/2 Square Phillips	Type A	2,000
4545902	12-8 x 1" XG Pancake	2/2 Square Phillips	Sharp Pt.	400
1545898	12-8 x 1-1/2" XG Pancake	2/2 Square Phillips	Sharp Pt.	3,000
1545907	12-8 x 2" XG Pancake	2/2 Square Phillips	Sharp Pt.	2,000
1545904	12-8 x 1" XG Low Profile	2/2 Square Phillips	Sharp Pt.	4,000
1545899	12-8 x 1-1/2" XG Low Profile	2/2 Square Phillips	Sharp Pt.	3,000
1545908	12-8 x 2" XG Low Profile	2/2 Square Phillips	Sharp Pt.	2,000
1545886	12 x 1" Pancake	2/2 Square Phillips	Type A	2,500
790272	10 x 1" 304 SS Pancake	#2 Phillips	Type A	2,500
1297583	10 x 2" 304 SS Pancake	#2 Phillips	Type A	2,500
Metal to Metal Application				
1545832	10-16 x 1" Pancake	2/2 Square Phillips	SD2	5,000
1545823	10-16 x 1-1/2" Pancake	2/2 Square Phillips	SD2	2,500
1545841	10-16 x 2" Pancake	2/2 Square Phillips	SD2	2,000
1545849	12-14 x 1" Pancake	2/2 Square Phillips	SD2	2,500
1545855	12-24 x 1-1/2" Pancake	2/2 Square Phillips	SD5	2,500

In-Stock
In-Stock

Pancake Self-Tappers
Material: Zinc and *Stainless* Available

#2 Phil. Combo Drive 1"
1-1/2"

Wafers/X-treme Lo Self-Tappers
Material: Zinc and *Stainless* Available

#2 Phil. Combo Drive 1"
1-1/2"

Pancake Self-Driller
Material: Zinc and *Stainless* Available

#2 Phil. Combo Drive 1"
1-1/2"

Wafers/X-treme Lo Self-Driller
Material: Zinc and *Stainless* Available

#2 Phil. Combo Drive 1"
1-1/2"

Part No.	Size	Description	Box Qty.
Pancake Self-Tappers			
1010250CKZP	1"	Pancake Self-Tappers Zinc	3,000
1015250CKZP	1-1/2"	Pancake Self-Tappers Zinc	2,500
1010250CKZPSS	1"	Pancake Self-Tappers Stainless Steel	3,000
1015250CKZPSS	1-1/2"	Pancake Self-Tappers Stainless Steel	2,500
Wafers/X-treme Lo Self-Tappers			
1010250CWZP	1"	Wafers/X-treme Lo Self-Tappers Zinc	3,000
1015250CWZP	1-1/2"	Wafers/X-treme Lo Self-Tappers Zinc	2,500
1010250CWZPSS	1"	Wafers/X-treme Lo Self-Tappers Stainless Steel	3,000
1015250CWZPSS	1-1/2"	Wafers/X-treme Lo Self-Tappers Stainless Steel	2,500
Pancake Self-Driller			
1010250CKSD3	1"	Pancake Self-Driller Zinc	3,000
1015250CKSD3	1-1/2"	Pancake Self-Driller Zinc	2,500
1010250CKSD3SS	1"	Pancake Self-Driller Stainless Steel	3,000
1015250CKSD3SS	1-1/2"	Pancake Self-Driller Stainless Steel	2,500
Wafers/X-treme Lo Self-Driller			
1010250CWSD3	1"	Wafers/X-treme Lo Self-Driller Zinc	3,000
1015250CWSD3	1-1/2"	Wafers/X-treme Lo Self-Driller Zinc	2,500
1010250CWSD3SS	1"	Wafers/X-treme Lo Self-Driller Stainless Steel	3,000
1015250CWSD3SS	1-1/2"	Wafers/X-treme Lo Self-Driller Stainless Steel	2,500

Recommended Drivers

#2 Mod. Phillips Combo Driver

Concealers

#10, #12, & 1/4" PIERCING POINTS AND DRILL POINTS

CONCEALOR® low profile head fasteners are engineered to perform in a variety of applications. They are specified in many metal roofing systems to attached SSR clips to metal or wood. They are easy to install and provides optimal strength.

Wood or Thin Metal

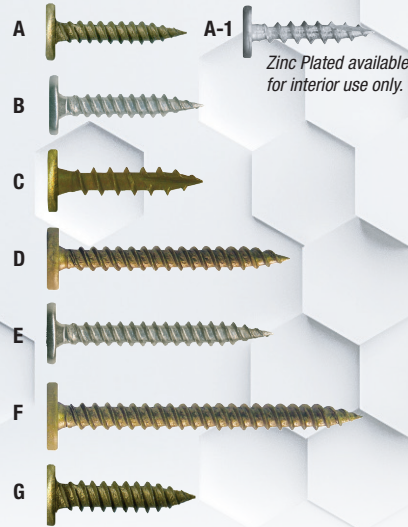

Part No.	Description	Pkg. Qty.
A	#10-13 X 1" GP Long-life TRI-SEAL® coated	5,000 pcs
A-1	#10-9 X 1" Type 17 Zinc Plated I Interior Use Only	5,000 pcs
B	#10-13 X 1" GP 302 Stainless Steel	5,000 pcs
C	#10-9 X 1-1/8" TYPE 17 Long-life TRI-SEAL® coated	5,000 pcs
D	#10-13 X 1-1/2" GP Long-life TRI-SEAL® coated	3,000 pcs
E	#10-13 X 1-1/2" GP 302 Stainless Steel	3,000 pcs
F	#10-13 X 2" GP Long-life TRI-SEAL® coated	1,500 pcs
G	#12-11 X 1" GP Long-life TRI-SEAL® coated	5,000 pcs

Metal Substrates



Part No.	Description	Pkg. Qty.
H	#10-16 X 5/8" DP3 .0003" Zinc and Yellow	5,000 pcs
I	#10-24 X 5/8" DP3 .0003" Zinc and Yellow	5,000 pcs
J	#10-16 X 1" DP3 Long-Life TRI-SEAL® coated	5,000 pcs
K	#10-16 X 1" DP3 410 Stainless Steel	5,000 pcs
L	#10-16 X 1-1/2" DP3 Long-Life TRI-SEAL® coated	3,000 pcs
M	#10-16 x 2" DP3 Long-Life TRI-SEAL® coated	1,500 pcs
N	#12-14 X 1" DP3 Long-Life TRI-SEAL® coated	5,000 pcs
O	#12-24 X 1-1/4" DP5 Long-Life TRI-SEAL® coated	4,000 pcs
O	#12-24 X 1-1/2" DP5 Long-Life TRI-SEAL® coated	4,000 pcs
P	1/4-14 X 1" DP3 Long-Life TRI-SEAL® coated	2,500 pcs

Bagged 250 pcs. per bag for your convenience!

Part No.	Description	Pkg. Qty.
A	#10-9 X 1-1/8" ULP (CS) Long-life TRI-SEAL™ coated	5,000
B	#10-9 X 1-1/8" ULP (CS) Zinc Plated Interior Use Only	5,000
C	#10-9 X 1-1/8" ULP (410 SS) Passivated	5,000
D	#10-9 X 1-5/8" ULP (CS) Long-life TRI-SEAL™ coated	3,000
E	#10-9 X 2-1/8" ULP(CS) Long-life TRI-SEAL™ coated	1,500



Zinc Plated available for interior use only.

Quik Drive® Screws

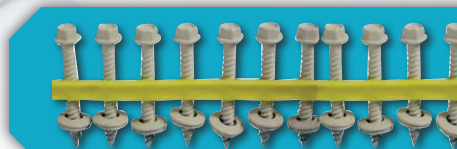

SIMPSON Strong-Tie

Collated Screws for the QuikDrive® System

HG Metal Roofing/Siding Panel Screw



Class 55 galvanized coating, Type-17 point

HJ Metal Roofing/Siding Panel Screw

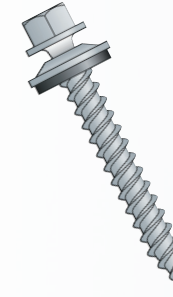

Type 305 stainless steel

PCSD Standing-Seam-Roofing Panel Clip Screw

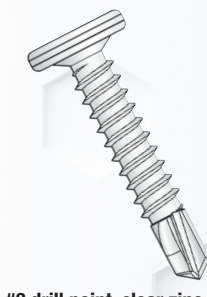

#3 drill point, clear zinc or Quik Guard® coating and Type 410 stainless steel

PC Standing-Seam-Roofing Panel Clip Screw

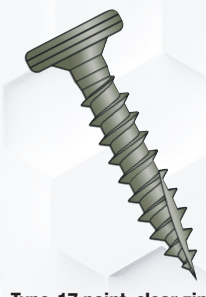

Type-17 point, clear zinc or Quik Guard® coating and Type 410 stainless steel

Strong-Drive® SELF-DRILLING X METAL Screw

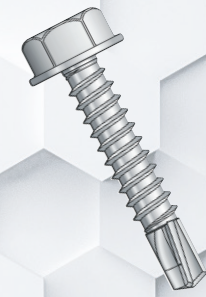

5/16" hex head, Quik Guard® and clear zinc coating

Strong-Drive® XM MEDIUM-HEAD METAL Screw

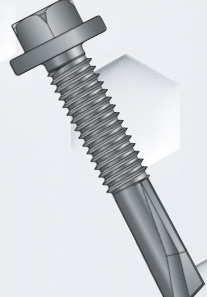

Quik Guard® coating

SIMPSON Strong-Tie

HG Metal Roofing/Siding Panel Screw

Common Applications:
Metal roofing/siding panels to wood

Features

- 1/4" hex head
- EPDM-backed washer
- Type-17 point for timber and light-steel battens
- Belt collated for the Quik Drive® BGP300 System

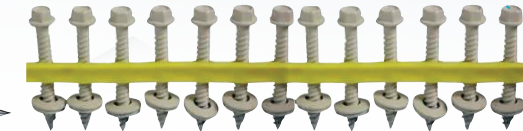
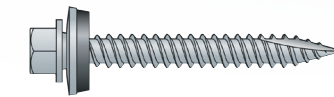

Color options available. (See Chart)

PART NO.	SHANK SIZE	SIZE	PACK QTY	BGP300
HG112WT10	#10	1-1/2"	2,500 pc	✓

SIMPSON Strong-Tie

BGP300 Metal-Roofing/Siding System For HG Metal Roofing/Siding Panel Screws



Kits Includes:

- BGP300 Metal-Roofing/Siding Attachment
- 2 profile guides (flat and AG Panel)
- 2 lobular hex-head driver bits (1/4" and 5/16")
- 16" extension for stand-up driving
- Belt hook fastener-strip holder
- Rugged tool case to protect your equipment on the jobsite



Applications:

Exposed-fastener metal roofing to wood, metal siding to wood

- Patented belt collation enables auto-feed fastening of screws with EPDM-backed washers (U.S. Patent 6,783,001)
- Profile guide on nosepiece ensures uniform screw placement
- Extension enables stand-up fastening on roofs
- Depth control prevents over-driving
- Designed to eliminate skipped screws, reducing screw waste (patent pending)

Available Colors



If we don't have it... You don't need it!

Loveland 970.663.0304

Denver 970.829.6473

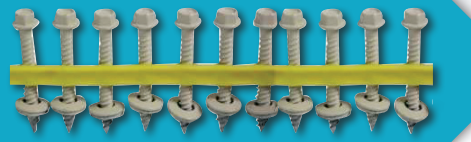

SIMPSON
Strong-Tie

PC Standing-Seam-Roofing Panel Clip Screw

Common Applications:
Standing-seam-roofing panel clips to wood

Features

- Pancake head
- #2 square drive (driver bit in each box; replacement bit model BIT2SU)
- Type-17 point
- Straight collation

Quik Guard® Coating

PART NO.	SHANK SIZE	SIZE	PACK QTY	PROPP150
PCQ1BS1012	#10	1"	1,500 pc	✓
PCQ112BS1012	#10	1-1/2"	1,500 pc	✓
PCQ1BS1211	#12	1"	1,500 pc	✓

PC Standing-Seam-Roofing Panel Clip Screw

Common Applications:
Standing-seam-roofing panel clips to wood

Features

- Pancake head
- #2 square drive (driver bit in each box; replacement bit model BIT2S)
- Type-17 point
- Straight collation
- Type 410 stainless steel is coated for additional corrosion protection

Type 410 Stainless Steel
Clear Zinc Coating

PART NO.	SHANK SIZE	SIZE	#2 DRIVE TYPE	PACK QTY	PROPP150
SSPC1BS1012	#10	1"	Standard	1,500 pc	✓
PC1BS1012	#10	1"	Standard	1,500 pc	✓
PC1BS1211	#12	1"	Standard	1,500 pc	✓

PCSD Standing-Seam-Roofing Panel Clip Screw

Common Applications:
Standing-seam-roofing panel clips to steel or sheet-steel sheathing to cold-formed steel

Features

- Pancake head
- #2 square drive (driver bit included in each box; replacement bit BIT2S; see p. 248 for more information)
- Drill point
- Straight collation
- Type 410 stainless steel is coated for additional corrosion protection
- This screw is also available in bulk for hand-drive installation; see p. 104 for details

Quik Guard® Coating
Type 410 Stainless Steel
Clear Zinc Coating

PART NO.	SHANK SIZE	SIZE	#2 DRIVE TYPE	PACK QTY	PROPP150
PCSDQ1S1016	#10	1"	Undersized	1,500 pc	✓
PCSDQ1S1214	#12	1"	Undersized	1,500 pc	✓
SSPCSD1S1016	#10	1"	Standard	1,500 pc	✓
PCSD1S1016	#10	1"	Standard	1,500 pc	✓
PCSD1S1214	#12	1"	Standard	1,500 pc	✓

PROPP150 Metal Roofing System



Kits Includes:

- PROPP150 Metal Roofing Attachment (also sold separately)
- Choice of DeWalt® or Makita® screwdriver motors
- Screw quiver for keeping screws at your fingertips
- Rugged tool case to protect your equipment on the jobsite

Drive These Collated Screws:

- PC Standing-Seam-Roofing Panel Clip Screw
- PCSD Standing-Seam-Roofing Panel Clip Screw
- Strong-Drive® Self-Drilling X Metal Screw



System Options:

- DeWalt® 2,000 rpm adjustable-torque screwdriver motor - PROPP150G2DATK
- Makita® 2,500 rpm screwdriver motor - PROPP150G2M25K

Applications:

Panel clips for standing-seam roofing, steel decking to structural steel members, panel flanges for snap-and-seam metal roofing

- Innovative Precision Placement™ nosepiece allows for easy location of the holes in standing seam metal roofing clips
- Auto-feed mechanism provides hands-free screw advancement, eliminating handling of individual screws, cutting installation time in half
- Screws available in four head styles with two levels of corrosion resistance

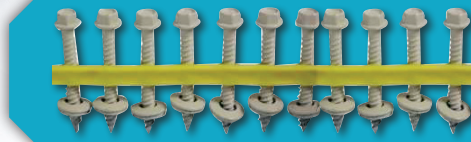

SIMPSON
Strong-Tie

Strong-Drive® SELF-DRILLING X METAL Screw

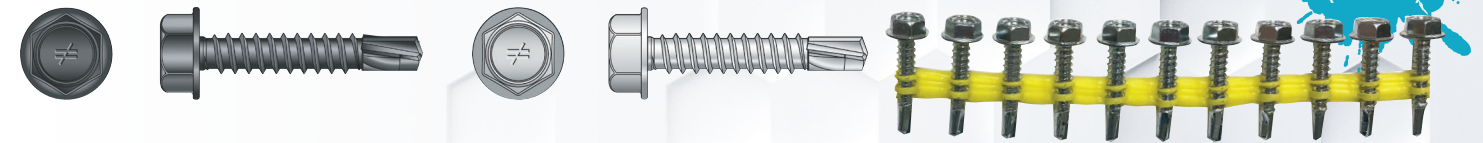

Color options available. (See Chart)

Common Applications:

1. Steel decking to structural steel;
2. Steel stitching ("side-lap" stitching);
3. Cold-formed steel framing

Features

- 5/16" hex head
- Drill point
- Hex washer head
- Straight collation
- This screw is also available in bulk for hand-drive installation

Quik Guard® Coating

Clear Zinc Coating

Quik Guard® Coating

PART NO.	SHANK SIZE	SIZE	POINT SIZE	PACK QTY	PRO SDX150
XQ1S1016	#10	1"	#3	1,500 pc	✓
XQ1S1214	#12	1"	#3	1,500 pc	✓
XQ114S1224	#12	1-1/4"	#5	1,500 pc	✓
XQ112S1224	#12	1-1/2"	#5	1,500 pc	✓
XU34S1016	#10	3/4"	#1	1,500 pc	✓
X1S1016	#10	1"	#3	1,500 pc	✓
X1S1214	#12	1"	#3	1,500 pc	✓
Strong-Drive® XM MEDIUM-HEAD METAL Screw					
XMQ114S1224	#12	1-1/4"	#5	1,500 pc	✓

Strong-Drive® XM MEDIUM-HEAD METAL Screw

Common Applications:

Steel decking to structural members involving wide or narrow valley; nestable or interlocking steel decking

Features

- 5/16" hex drive
- 1/2"-dia. hex washer head is ideal for narrow-channel steel decking
- Available only in 1 1/4" length with #5 drill point
- Available in Quik Guard® coating



PROSDX150 Steel-Decking System



Kits Includes:

- PROSDX150 Steel-Decking Attachment
- Extension for stand-up driving
- DeWalt® screwdriver motor
- Screw quiver for keeping screws at your fingertips

Drive These Collated Screws:

- Strong-Drive® XM Medium-Head Metal Screw
- Strong-Drive® Self-Drilling X Metal Screw



System Options:

- DeWalt® 2,000 rpm adjustable torque motor - PROSDX150ATK

Applications:

Steel deck fastening to structural steel members; narrow-valley nestable and interlocking steel decking; side-lap stitching

- Features a Precision Placement™ nosepiece for accurate driving
- One system for fastening steel decking to structural members and steel stitching
- Designed for both the Strong-Drive® XM Medium-Head Metal screw and the Strong-Drive® Self-Drilling X Metal screw

Deck Screws

Coarse Screws | Yellow Zinc



Recommended Drivers

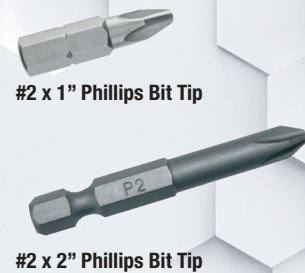

PART NO.	SIZE	BOX QTY
GS114	#6 x 1-1/4"	8M
GS112	#6 x 1-1/2"	6M
GS158	#6 x 1-5/8"	5M
GS200	#7 x 2"	3.5M
GS214	#7 x 2-1/4"	3M
GS212	#8 x 2-1/2"	2.5M
GS300	#8 x 3"	2M
GS312	#10 x 3-1/2"	1M
GS334	#10 x 3-3/4"	1M
GS400	#10 x 4"	1M

GuardDog® Exterior Wood Screws



Recommended Drivers included in each bucket

PART NO.	SIZE	BUCKET QTY
FMGD158-1750	1-5/8"	1,750 pc
FMGD002-1750	2"	1,750 pc
FMGD212-1750	2-1/2"	1,750 pc
FMGD003-1750	3"	1,750 pc
FMGD312-1350	3-1/2"	1,350 pc



Strong-Drive® WSNTL SUBFLOOR Screws



Wood-to-wood applications, yellow zinc coating, twin thread screws.



PART NO.	SHANK SIZE	SIZE	BIT SIZE	PACK QTY	PRO 300S
WSNTL134S	#8	1-3/4"	#3 Square	2,000 pc	✓
WSNTL2LS	#8	2"	#3 Square	2,000 pc	✓
WSNTL212S	#8	2-1/2"	#3 Square	1,500 pc	✓
WSNTL3S	#8	3"	#3 Square	1,700 pc	✓

Quick-Drive® PRO300S Decking System



Kits Includes:
 Quick-Drive® PRO300S Decking Attachment
 Quick-Drive® Extension
 Quick-Drive® Screw Quiver
 Quick-Drive® Tool Case - PRO Kits
 Screwdriver Motor
 Quick-Drive® Decking Nose Clip



Quick-Drive PRO300S Decking System
 SIMPSON PRO300SM25K



Rivets



Rivets

Color options available. (See Chart)

Steel Rivets

Description	Box Qty
#42 Steel Rivet (Grip Range: 1/16" to 1/8")	10,000
#44 Steel Rivet (Grip Range: 1/8" to 1/4")	10,000
#46 Steel Rivet (Grip Range: 5/16" to 3/8")	10,000



Stainless Steel Rivets

Description	Box Qty
#42 Stainless Steel Rivet (Grip Range: 1/16" to 1/8")	10,000
#44 Stainless Steel Rivet (Grip Range: 1/8" to 1/4")	10,000
#46 Stainless Steel Rivet (Grip Range: 5/16" to 3/8")	10,000

Copper Rivets

Description	Box Qty
#42 Copper Rivet (Grip Range: 1/16" to 1/8")	10,000
#44 Copper Rivet (Grip Range: 1/8" to 1/4")	10,000
#46 Copper Rivet (Grip Range: 5/16" to 3/8")	10,000

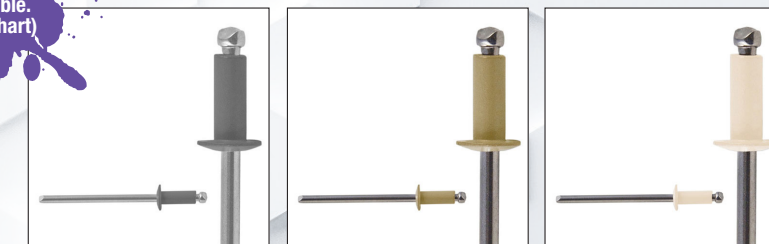

Slate Gray Rivet Warm White Rivet Snow Drift White Rivet

Colored Stainless Steel Rivets Stocked

Description	Bag Qty	Box Qty
#43 Colored SS Rivet (Grip Range: 5/16" to 3/8") Matte Black	250	5,000
#43 Colored SS Rivet (Grip Range: 5/16" to 3/8") Mansard Brown	250	5,000
#43 Colored SS Rivet (Grip Range: 5/16" to 3/8") Medium Bronze	250	5,000
#43 Colored SS Rivet (Grip Range: 5/16" to 3/8") Brandywine	250	5,000
#43 Colored SS Rivet (Grip Range: 5/16" to 3/8") Charcoal	250	5,000
#43 Colored SS Rivet (Grip Range: 5/16" to 3/8") Slate Gray	250	5,000
#43 Colored SS Rivet (Grip Range: 5/16" to 3/8") Colonial Red	250	5,000
#43 Colored SS Rivet (Grip Range: 5/16" to 3/8") Dark Bronze	250	5,000
#43 Colored SS Rivet (Grip Range: 5/16" to 3/8") Regal Blue	250	5,000
#43 Colored SS Rivet (Grip Range: 5/16" to 3/8") Warm White	250	5,000
#43 Colored SS Rivet (Grip Range: 5/16" to 3/8") Snow Drift White	250	5,000
#43 Colored SS Rivet (Grip Range: 5/16" to 3/8") Dark Bronze	250	5,000
#43 Colored SS Rivet (Grip Range: 5/16" to 3/8") Regal White	250	5,000
#43 Colored SS Rivet (Grip Range: 5/16" to 3/8") Ash Gray	250	5,000
#43 Colored SS Rivet (Grip Range: 5/16" to 3/8") Mansard Brown	250	5,000

Rivet Available Colors | In-Stock



Anchors

Tapcons

ORIGINAL BLUE TAPCON®

With over one billion anchors sold, the Original Blue Tapcon with Climaseal® coating provides:

- Superior holding strength
- Corrosion-resistance and long-lasting performance due to the innovative Climaseal® blue coating
- The ability to withstand harsh conditions

- Long-lasting performance
- A reputation for quality, strength and ease of installation from industry professionals



HWH Tapcons

PART NO.	DESCRIPTION
TAPCON 3139407	3/16" x 1-1/4" HWH Tapcon Anchor (500/Box)
TAPCON 3141407	3/16" x 1-3/4" HWH Tapcon Anchor (500/Box)
TAPCON 3143407	3/16" x 2-1/4" HWH Tapcon Anchor (500/Box)
TAPCON 3145407	3/16" x 2-3/4" HWH Tapcon Anchor (500/Box)
TAPCON 3147407	3/16" x 3-1/4" HWH Tapcon Anchor (500/Box)
TAPCON 3153407	1/4" x 1-1/4" HWH Tapcon Anchor (500/Box)
TAPCON 3155407	1/4" x 1-3/4" HWH Tapcon Anchor (500/Box)
TAPCON 3157407	1/4" x 2-1/4" HWH Tapcon Anchor (500/Box)
TAPCON 3159407	1/4" x 2-3/4" HWH Tapcon Anchor (500/Box)
TAPCON 3161407	1/4" x 3-1/4" HWH Tapcon Anchor (500/Box)
TAPCON 3163407	1/4" x 3-3/4" HWH Tapcon Anchor (500/Box)
TAPCON 3165407	1/4" x 4" HWH Tapcon Anchor (100/Box)
ELCO ELE465-100	1/4" x 4" Hex Tapcon (100/Box)
ELCO ELE475-100	1/4" x 5" HWH Ultracon (100/Box)
ELCO ELE485-100	1/4" x 6" HWH Ultracon (100/Box)

Flat Head Tapcons

PART NO.	DESCRIPTION
TAPCON 3169407	3/16" x 1-1/4" PFH Tapcon Anchor (500/Box)
TAPCON 3171407	3/16" x 1-3/4" PFH Tapcon Anchor (500/Box)
TAPCON 3173407	3/16" x 2-1/4" PFH Tapcon Anchor (500/Box)
TAPCON 3175407	3/16" x 2-3/4" PFH Tapcon Anchor (500/Box)
TAPCON 3177407	3/16" x 3-1/4" PFH Tapcon Anchor (500/Box)
TAPCON 3179407	3/16" x 3-3/4" PFH Tapcon Anchor (500/Box)
TAPCON 3183407	1/4" x 1-1/4" PFH Tapcon Anchor (500/Box)
TAPCON 3185407	1/4" x 1-3/4" PFH Tapcon Anchor (500/Box)
TAPCON 3187407	1/4" x 2-1/4" PFH Tapcon Anchor (500/Box)
TAPCON 3189407	1/4" x 2-3/4" PFH Tapcon Anchor (500/Box)
TAPCON 3191407	1/4" x 2-3/4" PFH Tapcon Anchor (500/Box)
TAPCON 3193407	1/4" x 3-3/4" PFH Tapcon Anchor (500/Box)
ELCO ELF460-100	1/4" x 4" Phillips Flat Head Ultracon Dst (100/Box)
ELCO ELF470-100	1/4" x 5" Phillips Flat Head Ultracon Dst (100/Box)
ELCO ELF480-100	1/4" x 6" Phillips Flat Head Ultracon Dst (100/Box)

Recommended SDS Plus Carbide Bit

DIAMETER	OAL	USE W/ FASTENER DIAMETER	USE W/ FASTENER LENGTH
5/32"	3-1/2"	3/16"	1-1/4" to 2"
5/32"	4-1/2"	3/16"	2-1/4" to 2-3/4"
5/32"	5-1/2"	3/16"	3-1/4" to 4"
5/32"	9"	3/16"	1-1/4" to 6"
3/16"	3-1/2"	1/4"	1-1/4" to 2"
3/16"	4-1/2"	1/4"	2-1/4" to 2-3/4"
3/16"	5-1/2"	1/4"	3-1/4" to 4"
3/16"	9"	1/4"	1-1/4" to 6"

Recommended Carbide Straight Shank Drill Bit

DIAMETER	OAL	USE W/ FASTENER DIAMETER	USE W/ FASTENER LENGTH
5/32"	3-1/2"	3/16"	1-1/4" to 2"
5/32"	4-1/2"	3/16"	2-1/4" to 2-3/4"
5/32"	5-1/2"	3/16"	3-1/4" to 4"
5/32"	9"	3/16"	1-1/4" to 6"
3/16"	3-1/2"	1/4"	1-1/4" to 2"
3/16"	4-1/2"	1/4"	2-1/4" to 2-3/4"
3/16"	5-1/2"	1/4"	3-1/4" to 4"
3/16"	9"	1/4"	1-1/4" to 6"

Zinc Nailon™ Pin Drive Anchor

Zinc Nailon™ anchors are low-cost, easy-to-install anchors for applications under static loads.

Features

- Available with carbon and stainless-steel pins
- Pin and head configuration designed to make anchor tamper-resistant

Recommended SDS Plus Bit or Straight Shank Carbide



3/16" x 2" (Usealbe) x 4" (OAL)

1/4" x 2" (Usealbe) x 4" (OAL)

1/4" x 4" (Usealbe) x 6" (OAL)

w/o Neo Washer

PART NO.	BULK ITEM #	DESCRIPTION	BOX QTY	BULK
ZN18078	ZN18078B	3/16" x 7/8" Zinc Nailon™ Pin Drive Anchor	100	3,000
ZN25034	ZN25034B	1/4" x 3/4" Zinc Nailon™ Pin Drive Anchor	100	2,000
ZN25100	ZN25100B	1/4" x 1" Zinc Nailon™ Pin Drive Anchor	100	1,500
ZN25114	ZN25114B	1/4" x 1-1/4" Zinc Nailon™ Pin Drive Anchor	100	1,500
ZN25112	ZN25112B	1/4" x 1-1/2" Zinc Nailon™ Pin Drive Anchor	100	1,000
ZN25200	ZN25200B	1/4" x 2" Zinc Nailon™ Pin Drive Anchor	100	1,000
ZN25212	ZN25212B	1/4" x 2-1/2" Zinc Nailon™ Pin Drive Anchor	100	1,000
ZN25300	ZN25300B	1/4" x 3" Zinc Nailon™ Pin Drive Anchor	100	1,000

w/ Neo Washer

PART NO.	DESCRIPTION
CSS31678	3/16" x 7/8" Zinc Nailon™ Pin Drive Anchor w/ a Neoprene Washer
CSS1434	1/4" x 3/4" Zinc Nailon™ Pin Drive Anchor w/ a Neoprene Washer
CSS14100	1/4" x 1" Zinc Nailon™ Pin Drive Anchor w/ a Neoprene Washer
CSS14114	1/4" x 1-1/4" Zinc Nailon™ Pin Drive Anchor w/ a Neoprene Washer
CSS14112	1/4" x 1-1/2" Zinc Nailon™ Pin Drive Anchor w/ a Neoprene Washer
CSS14200	1/4" x 2" Zinc Nailon™ Pin Drive Anchor w/ a Neoprene Washer
CSS14212	1/4" x 2-1/2" Zinc Nailon™ Pin Drive Anchor w/ a Neoprene Washer
CSS14300	1/4" x 3" Zinc Nailon™ Pin Drive Anchor w/ a Neoprene Washer

OMG Roofing Products



CD-10 Fastener

Recommended: SDS bit 7/32" x 1/2" deeper than fastener length

PART NO.	LENGTH	QTY
CD002	2"	500
CD212	2-1/2"	500
CD003	3"	500
CD312	3-1/2"	500
CD004	4"	500
CD412	4-1/2"	500
CD005	5"	500
CD512	5-1/2"	500
CD006	6"	500
CD007	7"	500
CD008	8"	500
CD009	9"	250
CD010	10"	250
CD011	11"	250
CD012	12"	250

#12 Standard RoofGrip Drill Point Fastener

PART NO.	LENGTH	QTY
RGDP158B	1-5/8"	1000
HHDP158B (Hex Head)	1"	1000
RGDP214B	2-1/4"	1000
HHDP214B (Hex Head)	2-1/4"	1000
RGDP003B	3"	1000
HHDP003B (Hex Head)	3"	1000
RGDP004B	4"	1000
HHDP004B (Hex Head)	4"	1000
RGDP005B	5"	1000
HHDP005B (Hex Head)	5"	1000
RGDP006B	6"	1000
HHDP006B (Hex Head)	6"	1000
RGDP007B	7"	1000
HHDP007B (Hex Head)	7"	1000
RGDP008B	8"	1000
HHDP008B (Hex Head)	8"	1000

Heavy Duty #14 Roofing Fastener

PART NO.	LENGTH	QTY
CRH14B	1-1/4"	1000
CRH134B	1-3/4"	1000
CRHD2B	2"	1000
CRHD3B	3"	1000
CRHD4B	4"	1000
CRHD5B	5"	500
CRHD6B	6"	500
CRHD7B	7"	500
CRHD8B	8"	500
CRHD9	9"	500
CRH10	10"	500
CRH11	11"	500
CRH12	12"	250
CRH14	14"	250
CRH16	16"	250
CRH18	18"	250
CRH20	20"	250
CRH21	21"	250
CRH22	22"	250
CRH24	24"	250

XHD #15 Roofing Fastener

PART NO.	LENGTH	QTY
XHD002B	2"	1000
XHD003B	3"	1000
XHD004B	4"	1000
XHD005B	5"	500
XHD006B	6"	500
XHD007B	7"	500
XHD008B	8"	500
XHD010B	10"	500
XHD012B	12"	500
XHD014	14"	250
XHD016	16"	250

HeadLok

Drill Point

PART NO.	QTY
FMHLDP006-250	250
FMHLDP008-250	250
FMHLDP010-250	250
FMHLDP012-250	250
FMHLDP014-250	250

Spade Point

PART NO.	QTY
FMHLSP158-500	500
FMHLSP278-500	500
FMHLSP312-250	250
FMHLSP004-250	250
FMHLSP412-250	250
FMHLSP005-250	250
FMHLSP512-250	250
FMHLSP006-250	250
FMHLSP612-250	250
FMHLSP007-250	250
FMHLSP712-250	250
FMHLSP008-250	250
FMHLSP010-250	250
FMHLSP012-250	250

Gimlet Point

PART NO.	LENGTH	QTY
FMHLGM334-250	3-3/4"	250
FMHLGM412-250	4-1/2"	250
FMHLGM005-250	5"	250
FMHLGM512-250	5-1/2"	250
FMHLGM007-250	7"	250
FMHLGM712-250	7-1/2"	250
FMHLGM008-250	8"	250
FMHLGM812-250	8-1/2"	250
FMHLGM009-250	9"	250
FMHLGM912-250	9-1/2"	250
FMHLGM010-250	10"	250
FMHLGM011-250	11"	250
FMHLGM012-250	12"	250
FMHLGM013-250	13"	250
FMHLGM014-250	14"	250
FMHLGM015-250	15"	250
FMHLGM016-250	16"	250
FMHLGM018-250	18"	250

Lite-Deck Fastener

PART NO.	LENGTH	QTY
TFSL258	2-5/8"	500
TFSL3	3"	500
TFSL4	4"	500
TFSL5	5"	250
TFSL6	6"	250
TFSL7	7"	250
TFSL8	8"	250
TFSL9	9"	125
TFSL10	10"	125
TFSL12	12"	125

Polymer GypTec

PART NO.	LENGTH	QTY
GYPTec025	2-1/2"	500
GYPTec030	3"	500
GYPTec035	3-1/2"	500
GYPTec040	4"	500
GYPTec045	4-1/2"	500
GYPTec050	5"	500
GYPTec055	5-1/2"	500
GYPTec060	6"	500
GYPTec065	6-1/2"	500
GYPTec070	7"	500
GYPTec075	7-1/2"	500
GYPTec080	8"	250
GYPTec085	8-1/2"	250
GYPTec090	9"	250
GYPTec095	9-1/2"	250
GYPTec100	10"	250
GYPTec105	10-1/2"	250
GYPTec110	11"	250
GYPTec115	11-1/2"	250
GYPTec120	12"	250

Purlin Fastener

PART NO.	LENGTH	QTY
PUR200	2"	1,000
PUR334	3-3/4"	500
PUR434	4-3/4"	500
PUR534	5-3/4"	500
PUR700	7"	500
PUR800	8"	500

Trufast Fasteners

TRUFAST



ROOFING FASTENER REFERENCE GUIDE

FASTENERS	APPLICATIONS	THREADS PER INCH/STYLE	HEAD STYLE	USE WITH	STANDARD LENGTHS	MATERIAL/FINISH	CODE APPROVALS
#12 DP ROOFING FASTENERS	STEEL (16 GAUGE OR THINNER)	13 SINGLE LEAD	#3 PHILLIPS FLAT TRUSS HEAD	METAL PLATE	1-5/8", 2-1/4", 2 7/8", 3-1/4", 3-3/4", 4-1/2", 5", 6", 7", 8"	CARBON STEEL BLACK E-Coat	FM, MIAMI-DADE CE - ETA 09/0375 State of Florida - FL#: 4500-R1
#12 DPH ROOFING FASTENERS	STEEL (16 GAUGE OR THINNER)	13 SINGLE LEAD	1/4" HEX HEAD	METAL PLATE	1-5/8", 2-1/4", 2 7/8", 3-1/4", 3-3/4", 4-1/2", 5", 6", 7", 8"	CARBON STEEL BLACK E-Coat	FM, MIAMI-DADE State of Florida - FL#: 4500-R1
#14 HD ROOFING FASTENERS	STEEL (16 - 24 GAUGE), WOOD, OR CONCRETE	13 SINGLE LEAD	#3 PHILLIPS FLAT TRUSS HEAD	METAL PLATE BATTEN BAR	1-1/2", 2", 2-1/2", 3", 3-1/2", 4", 4-1/2", 5", 5-1/2", 6", 7", 8", 9", 10", 11", 12"	CARBON STEEL BLACK E-Coat	FM, MIAMI-DADE CE - ETA 09/0375 State of Florida - FL#: 4500-R1
#14 STAINLESS STEEL HD ROOFING FASTENERS	STEEL (18 GAUGE OR THINNER) OR WOOD	13 SINGLE LEAD	#3 PHILLIPS FLAT TRUSS HEAD	METAL PLATE BATTEN BAR	1-1/2", 2", 3", 4", 5", 6", 7", 8", 9", 10", 12"	TRIMRITE® STAINLESS STEEL UNS S42010	FM, MIAMI-DADE CE - ETA 09/0375 State of Florida - FL#: 4500-R1
#15 EHD ROOFING FASTENERS	STEEL (18 GAUGE OR THINNER) OR WOOD	13 SINGLE LEAD BUTTRESS	#3 PHILLIPS FLAT TRUSS HEAD	METAL PLATE BATTEN BAR	1-1/4", 2", 3", 4", 5", 6", 7", 8", 9", 10", 11", 12", 14", 16", 18", 20", 22", 24"	CARBON STEEL BLACK E-Coat	FM, MIAMI-DADE CE - ETA 09/0375 State of Florida - FL#: 4500-R1
(PA) PRE-ASSEMBLED	STEEL (16 GAUGE OR THINNER) OR WOOD	13 SINGLE LEAD	1/4" HEX OR #3 PHILLIPS FLAT TRUSS HEAD	METAL PLATE	1-5/8", 2-1/4", 2-7/8", 3-1/4", 3-3/4", 4-1/2", 5", 6", 7", 8"	SCREW-CARBON STEEL & BLACK E-Coat; PLATE- GALVALUME	FM State of Florida - FL#: 4500-R1 MIAMI-DADE (DP Only)
1/4" CONCRETE SPIKE ROOFING FASTENER	CONCRETE	N/A	TRUSS HEAD	METAL PLATE BATTEN BAR	1-1/4", 1-1/2", 2", 2-1/2", 3", 3-1/2", 4", 4-1/2", 5-1/2", 6", 6-1/2", 7", 7-1/2", 8", 9", 10", 11", 12", 13", 14", 15", 16"	CARBON STEEL BLACK E-Coat	FM
FLUTED CONCRETE NAIL	CONCRETE, MASONRY BLOCK & BRICK	N/A	FLAT TRUSS HEAD	METAL PLATE BATTEN BAR	1-1/2", 2", 2-1/2", 3", 3-1/2", 4", 4-1/2", 5", 5-1/2", 6", 7", 8", 9", 10", 11", 12"	CARBON STEEL BLACK E-Coat	FM, MIAMI-DADE CE - ETA 09/0375 State of Florida - FL#: 4500-R1
TL ROOFING FASTENERS	TECTUM® & LT. WT. CONCRETE	TAPERED ROOT WITH BUTTRESS	1/4" SQUARE DRIVE FLAT HEAD	METAL PLATE	2", 2-1/2", 3", 3-1/2", 4", 4-1/2", 5", 5-1/2", 6", 6-1/2", 7", 7-1/2", 8", 8-1/2", 9", 9-1/2", 10", 11", 12", 13", 14"	NYLON	FM MIAMI-DADE State of Florida - FL#: 4500-R1
#12 PURLIN ROOFING FASTENERS	STEEL (3/16" THICK OR THINNER)	24 SINGLE LEAD	#3 SQUARE DRIVE PANCAKE HEAD	METAL PLATE BATTEN BAR	1-3/8", 2-3/4", 3-3/4", 4-3/4", 5-3/4", 6-3/4", 7-3/4", 8-3/4"	CARBON STEEL BLACK E-Coat	FM, MIAMI-DADE CE - ETA 09/0375 State of Florida - FL#: 4500-R1
SIP LD FASTENER	CORRUGATED STEEL, WOOD & CONCRETE	10 SINGLE LEAD	T-STAR #30 PANCAKE HEAD	N/A	3", 3-1/2", 4", 4-1/4", 5", 5-1/2", 6", 6-1/2", 7", 7-1/2", 8", 8-1/2", 9", 10", 11", 12", 13", 14", 15", 16", 17", 18"	CARBON STEEL BLACK E-Coat	FM, MIAMI-DADE CE - ETA 09/0375 State of Florida - FL#: 4500-R1
SIP HD FASTENER	STRUCTURAL STEEL	20 SINGLE LEAD	T-STAR #30 PANCAKE HEAD	N/A	6", 8", 9-3/4", 11-3/4", 13-3/4"	CARBON STEEL BLACK E-Coat	FM, MIAMI-DADE CE - ETA 09/0375 State of Florida - FL#: 4500-R1
SIP TP FASTENER	WOOD	7 SINGLE LEAD	T-STAR #30 PANCAKE HEAD	N/A	2", 2-1/2", 3", 3-1/2", 4", 4-1/2", 5", 5-1/2", 6", 6-1/2", 7", 7-1/2", 8", 8-1/2", 9", 10", 11", 12", 13", 14", 15", 16", 17", 18"	CARBON STEEL BLACK E-Coat	FM, MIAMI-DADE CE - ETA 09/0375 State of Florida - FL#: 4500-R1

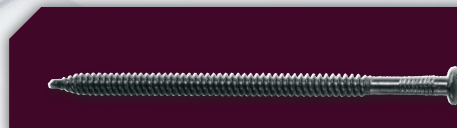

BASE SHEET FASTENERS	APPLICATIONS	STANDARD LENGTHS	HEAD/DISK DIAMETER	MATERIAL / FINISH	CODE APPROVALS
TWIN LOC-NAIL	LWIC, TECTUM® & GYPSUM	1.4", 1.8", 2.8", 3.8", 4.8"	2.7"	GALVALUME® - PLATE, COATED STEEL - TUBE STAINLESS STEEL - LOCKING STAPLE	FM MIAMI-DADE
FM-90	LWIC & GYPSUM	1.7"	2.7"	GALVALUME® - PLATE POLYMER COATED STEEL - LEGS	FM MIAMI-DADE
FM-75	LWIC, NVS CONCRETE & GYPSUM	1.2"	2.7"	GALVALUME® - PLATE POLYMER COATED STEEL - LEGS	FM MIAMI-DADE
FM-290	LWIC	1.7"	3.6" X 2.5"	GALVALUME® - PLATE POLYMER COATED STEEL - LEGS	FM MIAMI-DADE
DO ALL LOC-NAIL	GYPSUM BOARD (USE WITH METAL CAP FOR BASE SHEET ATTACHMENT)	1.375", 1.75"	.435" HEAD	ZINC PLATED OR STAINLESS STEEL	N/A

PLATESS	APPLICATIONS	USE WITH	CODE APPROVALS	BARS	FEATURE	THICKNESS	MATERIAL	CODE APPROVALS
3" METAL INSULATION PLATE	COVERBOARDS, INSULATION, & BUR BASE SHEETS TO THE SUBSTRATE	DP, HD, HD-SS, EHD, TG, TS250	FM, MIAMI-DADE CE - ETA 09/0375 State of Florida - FL#: 4500-R1	TB-50 TERMINATION	SEALANT LEDGE	.050"	EXTRUDED ALUMINUM	N/A
3" RECESSED METAL INSULATION PLATE	INSULATION TO THE SUBSTRATE	DP, DPH, HD, HD-SS, EHD, TS250	FM, MIAMI-DADE CE - ETA 09/0375 State of Florida - FL#: 4500-R1	TB-75 TERMINATION	SEALANT LEDGE	.075"	EXTRUDED ALUMINUM	N/A
3" TL INSULATION PLATE	COVERBOARDS, INSULATION, BUR BASE SHEETS TO CEMENTITIOUS WOOD FIBER, GYPSUM, & LIGHTWEIGHT CONCRETE SUBSTRATE	TL	FM MIAMI-DADE State of Florida - FL#: 4500-R1	TB-75-SS TERMINATION	SEALANT LEDGE	.075"	STAINLESS STEEL	N/A
2" METAL SEAM PLATE	REINFORCED & NON-REINFORCED SINGLE-PLY MEMBRANES TO THE SUBSTRATE	HD, HD-SS, EHD, PF, TG, TS250	FM, MIAMI-DADE CE - ETA 09/0375 State of Florida - FL#: 4500-R1	TB-90 TERMINATION	FLAT	.090"	EXTRUDED ALUMINUM	N/A
2" BARBED SEAM PLATE	REINFORCED SINGLE-PLY & MODIFIED BITUMINOUS MEMBRANES TO THE SUBSTRATE	HD, HD-SS, EHD, PF, TG, TS250	FM, MIAMI-DADE CE - ETA 09/0375 State of Florida - FL#: 4500-R1	TB-100 TERMINATION	SEALANT LEDGE	.100"	EXTRUDED ALUMINUM	N/A
2" TL SEAM PLATE	REINFORCED SINGLE-PLY & MODIFIED BITUMINOUS MEMBRANES TO CEMENTITIOUS WOOD FIBER, GYPSUM, & LIGHTWEIGHT CONCRETE SUBSTRATE	TL	FM MIAMI-DADE State of Florida - FL#: 4500-R1	TB-125 TERMINATION	FLAT	.125"	EXTRUDED ALUMINUM OR STAINLESS STEEL	N/A
2.4" BARBED METAL SEAM PLATE	REINFORCED SINGLE-PLY & MODIFIED BITUMINOUS MEMBRANES TO THE SUBSTRATE	HD, HD-SS, EHD, PF, TG, TS250	FM, MIAMI-DADE CE - ETA 09/0375 State of Florida - FL#: 4500-R1	TB-125-SS TERMINATION	FLAT	.125"	STAINLESS STEEL	N/A
2.4" BARBED METAL SEAM PLATE (14 BARB)	REINFORCED SINGLE-PLY & MODIFIED BITUMINOUS MEMBRANES TO THE SUBSTRATE	HD, HD-SS, EHD, PF, TG, TS250	FM, MIAMI-DADE CE - ETA 09/0375 State of Florida - FL#: 4500-R1	RD-100 DRAIN	STONE BALLAST RETAINER	.100"	EXTRUDED ALUMINUM	N/A
2.4" SCOOP SEAM PLATE	REINFORCED SINGLE-PLY & MODIFIED BITUMINOUS MEMBRANES TO THE SUBSTRATE	HD, HD-SS, EHD, PF, TG, TS250	FM, MIAMI-DADE CE - ETA 09/0375 State of Florida - FL#: 4500-R1	BATTEN BAR	FLAT OR RECESSED	.043"	GALVALUME®	FM MIAMI-DADE CE - ETA 09/0375 State of Florida - FL#: 4500-R1
TWIN LOC COILED BATTEN BAR	TWIN LOC-NAIL BATTEN FASTENER					.040"	GALVALUME®	MIAMI-DADE

TRUFast Shorty Tool™

- Allows one-hand operation to drive fasteners on flat or sloping surfaces.
- For use with #3 Phillips head and Hex head fasteners.
- Easy depth control adjustment helps ensure proper fastener tightness.
- Compact and lightweight.
- For use on Milwaukee 6792-20 Screwgun with threaded nosepiece.

TRUFast PA System™

- PA (pre-assembled) fasteners are faster to install than individual screws and plates.
- System and tools require no special training.
- Improves ergonomics and worker productivity.
- Simple, lightweight, and portable Standup Tool.
- Reliable and economical as compared with cumbersome, complicated automated equipment.

TRUFAST — HD #14 Heavy Duty Drill Point, #3 Phillips Truss Head, Black E-coat

The TRUFAST #14 HD Fastener is an ideal "all-purpose fastener" for use in corrugated steel, structural concrete, and wood roof decks for insulation or lap attachment.

PART NO.	DESCRIPTION	PKG QTY/TYPER
HD-1500	1-1/2" HD #14 Heavy Duty Drill Point, #3 Phillips Truss Head, Black E-Coat	1,000 / Bucket
HD-2000	2" HD #14 Heavy Duty Drill Point, #3 Phillips Truss Head, Black E-Coat	1,000 / Bucket
HD-2500	2-1/2" HD #14 Heavy Duty Drill Point, #3 Phillips Truss Head, Black E-Coat	1,000 / Bucket
HD-3000	3" HD #14 Heavy Duty Drill Point, #3 Phillips Truss Head, Black E-Coat	1,000 / Bucket
HD-3500	3-1/2" HD #14 Heavy Duty Drill Point, #3 Phillips Truss Head, Black E-Coat	1,000 / Bucket
HD-4000	4" HD #14 Heavy Duty Drill Point, #3 Phillips Truss Head, Black E-Coat	1,000 / Bucket
HD-4500	4-1/2" HD #14 Heavy Duty Drill Point, #3 Phillips Truss Head, Black E-Coat	1,000 / Bucket
HD-5000	5" HD #14 Heavy Duty Drill Point, #3 Phillips Truss Head, Black E-Coat	1,000 / Bucket
HD-5500	5-1/2" HD #14 Heavy Duty Drill Point, #3 Phillips Truss Head, Black E-Coat	1,000 / Bucket
HD-6000	6" HD #14 Heavy Duty Drill Point, #3 Phillips Truss Head, Black E-Coat	1,000 / Bucket
HD-7000	7" HD #14 Heavy Duty Drill Point, #3 Phillips Truss Head, Black E-Coat	500 / Bucket
HD-8000	8" HD #14 Heavy Duty Drill Point, #3 Phillips Truss Head, Black E-Coat	500 / Bucket
HD-9000	9" HD #14 Heavy Duty Drill Point, #3 Phillips Truss Head, Black E-Coat	250 / Bucket
HD-10000	10" HD #14 Heavy Duty Drill Point, #3 Phillips Truss Head, Black E-Coat	250 / Bucket
HD-11000	11" HD #14 Heavy Duty Drill Point, #3 Phillips Truss Head, Black E-Coat	250 / Bucket
HD-12000	12" HD #14 Heavy Duty Drill Point, #3 Phillips Truss Head, Black E-Coat	250 / Bucket

DPH #12 Drill Point, 1/4" Hex Head, Black E-coat

TRUFAST #12 DPH Fasteners are designed for insulation attachment to 16-18 gauge steel roof decks.

PART NO.	DESCRIPTION	PKG QTY/TYPER
DPH-1625	1-5/8" DPH #12 Drill Point, 1/4" Hex Head, Black E-Coat	1,000 / Bucket
DPH-2250	2-1/4" DPH #12 Drill Point, 1/4" Hex Head, Black E-Coat	1,000 / Bucket
DPH-2875	2-7/8" DPH #12 Drill Point, 1/4" Hex Head, Black E-Coat	1,000 / Bucket
DPH-3250	3-1/4" DPH #12 Drill Point, 1/4" Hex Head, Black E-Coat	1,000 / Bucket
DPH-3750	3-3/4" DPH #12 Drill Point, 1/4" Hex Head, Black E-Coat	1,000 / Bucket
DPH-4500	4-1/2" DPH #12 Drill Point, 1/4" Hex Head, Black E-Coat	1,000 / Bucket
DPH-5000	5" DPH #12 Drill Point, 1/4" Hex Head, Black E-Coat	1,000 / Bucket
DPH-6000	6" DPH #12 Drill Point, 1/4" Hex Head, Black E-Coat	1,000 / Bucket
DPH-7000	7" DPH #12 Drill Point, 1/4" Hex Head, Black E-Coat	500 / Bucket
DPH-8000	8" DPH #12 Drill Point, 1/4" Hex Head, Black E-Coat	500 / Bucket

PFC Purlin Fasteners, 1/4" Sq. Drive, Pancake Head, Black E-coat

The TRUFAST #12 PFC Purling Fasteners are designed for attaching single-ply membrane systems to structural steel purlings up to 3-16" Thick.

PART NO.	DESCRIPTION	PKG QTY/TYPER
PFC-1375	1-3/8" PFC Purling Fasteners, 1/4" Sq. Drive, Pancake Head, Black E-Coat	2,500 / Bucket
PFC-2750	2-3/4" PFC Purling Fasteners, 1/4" Sq. Drive, Pancake Head, Black E-Coat	1,000 / Bucket
PFC-3750	3-3/4" PFC Purling Fasteners, 1/4" Sq. Drive, Pancake Head, Black E-Coat	1,000 / Bucket
PFC-4750	4-3/4" PFC Purling Fasteners, 1/4" Sq. Drive, Pancake Head, Black E-Coat	1,000 / Bucket
PFC-5750	5-3/4" PFC Purling Fasteners, 1/4" Sq. Drive, Pancake Head, Black E-Coat	1,000 / Bucket
PFC-6750	6-3/4" PFC Purling Fasteners, 1/4" Sq. Drive, Pancake Head, Black E-Coat	1,000 / Bucket
PFC-7750	7-3/4" PFC Purling Fasteners, 1/4" Sq. Drive, Pancake Head, Black E-Coat	500 / Bucket
PFC-8750	8-3/4" PFC Purling Fasteners, 1/4" Sq. Drive, Pancake Head, Black E-Coat	500 / Bucket

Fluted Nail Concrete Fasteners, Black E-coat

The TRUFAST Fluted Concrete Nail is designed to secure insulation, coverboards, single-ply roof membrane, wood, and steel to structural concrete.

Recommended:
SDS bit 3/16" x 1/2" deeper than fastener length

PART NO.	DESCRIPTION	PKG QTY/TYPER
TG-1500	1-1/2" Fluted Nail Concrete Fasteners, Black E-Coat	1,000 / Bucket
TG-2000	2" Fluted Nail Concrete Fasteners, Black E-Coat	1,000 / Bucket
TG-2500	2-1/2" Fluted Nail Concrete Fasteners, Black E-Coat	1,000 / Bucket
TG-3000	3" Fluted Nail Concrete Fasteners, Black E-Coat	1,000 / Bucket
TG-3500	3-1/2" Fluted Nail Concrete Fasteners, Black E-Coat	1,000 / Bucket
TG-4000	4" Fluted Nail Concrete Fasteners, Black E-Coat	1,000 / Bucket
TG-4500	4-1/2" Fluted Nail Concrete Fasteners, Black E-Coat	1,000 / Bucket
TG-5000	5" Fluted Nail Concrete Fasteners, Black E-Coat	1,000 / Bucket
TG-5500	5-1/2" Fluted Nail Concrete Fasteners, Black E-Coat	1,000 / Bucket
TG-6000	6" Fluted Nail Concrete Fasteners, Black E-Coat	1,000 / Bucket
TG-7000	7" Fluted Nail Concrete Fasteners, Black E-Coat	500 / Bucket
TG-8000	8" Fluted Nail Concrete Fasteners, Black E-Coat	500 / Bucket
TG-9000	9" Fluted Nail Concrete Fasteners, Black E-Coat	250 / Bucket
TG-10000	10" Fluted Nail Concrete Fasteners, Black E-Coat	250 / Bucket
TG-11000	11" Fluted Nail Concrete Fasteners, Black E-Coat	250 / Bucket
TG-12000	12" Fluted Nail Concrete Fasteners, Black E-Coat	250 / Bucket

TRUFAST — SIPLD Structural Insulated Panel Fasteners

The TRUFAST Fluted Concrete Nail is designed to secure insulation, coverboards, single-ply roof membrane, wood, and steel to structural concrete.

Recommended:
SDS bit 1/4" x 1/2" deeper than fastener length

PART NO.	DESCRIPTION	PKG QTY/TYPER
SIPLD-3000	3" SIPLD Structural Insulated Panel Fasteners, Light-Duty #2 Drill Point	500 / Bucket
SIPLD-3500	3-1/2" SIPLD Structural Insulated Panel Fasteners, Light-Duty #2 Drill Point	500 / Bucket
SIPLD-4000	4" SIPLD Structural Insulated Panel Fasteners, Light-Duty #2 Drill Point	500 / Bucket
SIPLD-4500	4-1/2" SIPLD Structural Insulated Panel Fasteners, Light-Duty #2 Drill Point	500 / Bucket
SIPLD-5000	5" SIPLD Structural Insulated Panel Fasteners, Light-Duty #2 Drill Point	500 / Bucket
SIPLD-5500	5-1/2" SIPLD Structural Insulated Panel Fasteners, Light-Duty #2 Drill Point	500 / Bucket
SIPLD-6000	6" SIPLD Structural Insulated Panel Fasteners, Light-Duty #2 Drill Point	500 / Bucket
SIPLD-6500	6-1/2" SIPLD Structural Insulated Panel Fasteners, Light-Duty #2 Drill Point	500 / Bucket
SIPLD-7000	7" SIPLD Structural Insulated Panel Fasteners, Light-Duty #2 Drill Point	500 / Bucket
SIPLD-7500	7-1/2" SIPLD Structural Insulated Panel Fasteners, Light-Duty #2 Drill Point	500 / Bucket
SIPLD-8000	8" SIPLD Structural Insulated Panel Fasteners, Light-Duty #2 Drill Point	500 / Bucket
SIPLD-8500	8-1/2" SIPLD Structural Insulated Panel Fasteners, Light-Duty #2 Drill Point	250 / Bucket
SIPLD-9000	9" SIPLD Structural Insulated Panel Fasteners, Light-Duty #2 Drill Point	250 / Bucket
SIPLD-9500	9-1/2" SIPLD Structural Insulated Panel Fasteners, Light-Duty #2 Drill Point	250 / Bucket
SIPLD-10000	10" SIPLD Structural Insulated Panel Fasteners, Light-Duty #2 Drill Point	250 / Bucket
SIPLD-11000	11" SIPLD Structural Insulated Panel Fasteners, Light-Duty #2 Drill Point	250 / Bucket
SIPLD-12000	12" SIPLD Structural Insulated Panel Fasteners, Light-Duty #2 Drill Point	250 / Bucket
SIPLD-13000	13" SIPLD Structural Insulated Panel Fasteners, Light-Duty #2 Drill Point	250 / Carton
SIPLD-14000	14" SIPLD Structural Insulated Panel Fasteners, Light-Duty #2 Drill Point	250 / Carton
SIPLD-15000	15" SIPLD Structural Insulated Panel Fasteners, Light-Duty #2 Drill Point	250 / Carton
SIPLD-16000	16" SIPLD Structural Insulated Panel Fasteners, Light-Duty #2 Drill Point	250 / Carton
SIPLD-18000	18" SIPLD Structural Insulated Panel Fasteners, Light-Duty #2 Drill Point	250 / Carton

1/4" Dia. Roofing Spike, Black E-coat

The TRUFAST Concrete Spike is a one-piece, vibration-resistant anchor designed to fasten insulation, single-ply roof membrane, wood, and steel to structural concrete roof decks.

PART NO.	DESCRIPTION	PKG QTY/TYPER
TS250-1250	1-1/4" x 1/4" Diameter Concrete Spike, Black E-Coat	500 / Bucket
TS250-1500	1-1/2" x 1/4" Diameter Concrete Spike, Black E-Coat	500 / Bucket
TS250-2000	2" x 1/4" Diameter Concrete Spike, Black E-Coat	500 / Bucket
TS250-2500	2-1/2" x 1/4" Diameter Concrete Spike, Black E-Coat	500 / Bucket
TS250-3000	3" x 1/4" Diameter Concrete Spike, Black E-Coat	500 / Bucket
TS250-3500	3-1/2" x 1/4" Diameter Concrete Spike, Black E-Coat	500 / Bucket
TS250-4000	4" x 1/4" Diameter Concrete Spike, Black E-Coat	500 / Bucket
TS250-4500	4-1/2" x 1/4" Diameter Concrete Spike, Black E-Coat	500 / Bucket
TS250-5000	5" x 1/4" Diameter Concrete Spike, Black E-Coat	500 / Bucket
TS250-5500	5-1/2" x 1/4" Diameter Concrete Spike, Black E-Coat	500 / Bucket
TS250-6000	6" x 1/4" Diameter Concrete Spike, Black E-Coat	250 / Bucket
TS250-6500	6-1/2" x 1/4" Diameter Concrete Spike, Black E-Coat	250 / Bucket
TS250-7000	7" x 1/4" Diameter Concrete Spike, Black E-Coat	250 / Bucket
TS250-7500	7-1/2" x 1/4" Diameter Concrete Spike, Black E-Coat	250 / Bucket
TS250-8000	8" x 1/4" Diameter Concrete Spike, Black E-Coat	250 / Bucket
TS250-9000	9" x 1/4" Diameter Concrete Spike, Black E-Coat	250 / Bucket
TS250-10000	10" x 1/4" Diameter Concrete Spike, Black E-Coat	250 / Bucket
TS250-11000	11" x 1/4" Diameter Concrete Spike, Black E-Coat	100 / Bucket
TS250-12000	12" x 1/4" Diameter Concrete Spike, Black E-Coat	100 / Bucket
TS250-13000	13" x 1/4" Diameter Concrete Spike, Black E-Coat	100 / Bucket
TS250-14000	14" x 1/4" Diameter Concrete Spike, Black E-Coat	100 / Bucket
TS250-15000	15" x 1/4" Diameter Concrete Spike, Black E-Coat	100 / Bucket
TS250-16000	16" x 1/4" Diameter Concrete Spike, Black E-Coat	100 / Bucket

Stress Plates & Batten Bars

PART NO.	DESCRIPTION	PKG QTY/TYPER
MP-2-TF	2" Seam Plate	1,000 / Bucket
MPB-2-TF	2" Barbed Seam Plate	1,000 / Bucket
MPB-2400	2.4" Barbed Seam Plate	1,000 / Bucket
MP-3-TF	3" Insulation Plate	1,000 / Bucket
MPI-3-TF	3" Recessed Insulation Plate	1,000 / Bucket

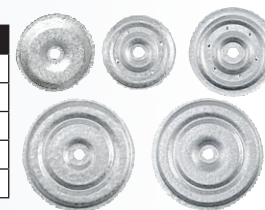

PART NO.	DESCRIPTION	PKG QTY/TYPER
BB-18	10" Galvalume Seam/Batten Bar	500 / 3.5" Tube
BB-18-R	10" Recessed Galvalume Seam/Batten Bar	500 / 3.5" Tube

TL Lightweight Nylon Fasteners

The TRUFAST TL Fastener is a glass-filled nylon auger fastener designed to secure roof insulation and single-ply membrane to gypsum and cementitious wood fiber (i.e. Tectum) decks.



PART NO.	DESCRIPTION	QTY
TL-2000	2" TL Lightweight Nylon Fasteners	500
TL-2500	2-1/2" TL Lightweight Nylon Fasteners	500
TL-3000	3" TL Lightweight Nylon Fasteners	500
TL-3500	3-1/2" TL Lightweight Nylon Fasteners	500
TL-4000	4" TL Lightweight Nylon Fasteners	500
TL-4500	4-1/2" TL Lightweight Nylon Fasteners	500
TL-5000	5" TL Lightweight Nylon Fasteners	500
TL-5500	5-1/2" TL Lightweight Nylon Fasteners	500
TL-6000	6" TL Lightweight Nylon Fasteners	500
TL-6500	6-1/2" TL Lightweight Nylon Fasteners	500
TL-7000	7" TL Lightweight Nylon Fasteners	500
TL-7500	7-1/2" TL Lightweight Nylon Fasteners	500
TL-8000	8" TL Lightweight Nylon Fasteners	500
TL-8500	8-1/2" TL Lightweight Nylon Fasteners	500
TL-9000	9" TL Lightweight Nylon Fasteners	500
TL-9500	9-1/2" TL Lightweight Nylon Fasteners	500
TL-10000	10" TL Lightweight Nylon Fasteners	500
TL-11000	11" TL Lightweight Nylon Fasteners	500
TL-12000	12" TL Lightweight Nylon Fasteners	500
TL-13000	13" TL Lightweight Nylon Fasteners	500
TL-14000	14" TL Lightweight Nylon Fasteners	500

TL Plates



PART NO.	DESCRIPTION	PKG QTY/TYPER
TLP-2	2" Membrane TL Plate	1,000 / Carton
TLP-3	3" Membrane TL Plate	500 / Carton



Roofing Nails



Coil Nails

Electro-Galvanized (EG)

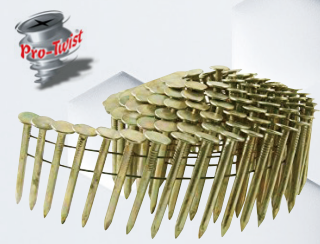

SIZE	DESCRIPTION
3/4" x .120	EG Coil Roofing Nails
7/8" x .120	EG Coil Roofing Nails
1-1/4" x .120	EG Coil Roofing Nails
1-1/2" x .120	EG Coil Roofing Nails
1-3/4" x .120	EG Coil Roofing Nails

Hot Dipped Galvanized (HDG)



PART NO.	SIZE	DESCRIPTION	QTY
CLWR102A	1-1/4"	HDG Ring Shank Coil Nail	3,600/Box
CLWR103A	1-1/2"	HDG Ring Shank Coil Nail	3,600/Box
CLWR104A	1-3/4"	HDG Ring Shank Coil Nail	3,600/Box

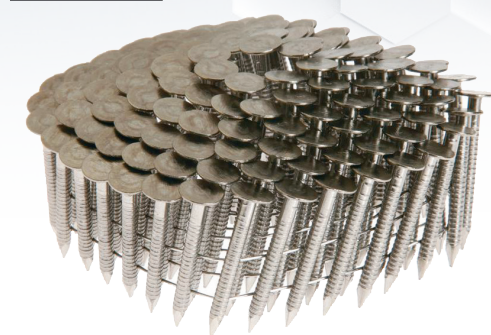

Stainless Steel



PART NO.	SIZE	DESCRIPTION	QTY
5RCS11	1-1/4"	Smooth Stainless Steel Coil Roofing Nails	3,600/Box
5RCS12	1-1/2"	Smooth Stainless Steel Coil Roofing Nails	3,600/Box
5RCS13	1-3/4"	Smooth Stainless Steel Coil Roofing Nails	3,600/Box
5RCR11	1-1/4"	Ring Barb Stainless Steel Coil Roofing Nails	3,600/Box
5RCR12	1-1/2"	Ring Barb Stainless Steel Coil Roofing Nails	3,600/Box
5RCR13	1-3/4"	Ring Barb Stainless Steel Coil Roofing Nails	3,600/Box

Best Choice for:

- Installation of 3 tab and architectural asphalt shingles
- installation of cedar roof shingles
- Long term corrosion resistance in harsh environmental conditions

- Corrosion resistant, durable, attractive
- Manufactured from T-304 stainless steel
- Manufactured with large slating heads & diamond points
- Compatible with most manufacturers 15° coil roofing nail guns
- Available in ring barb for maximum holding power

Staples

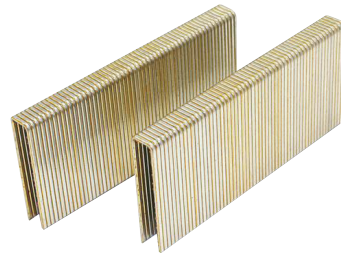

SIZE	DESCRIPTION
7/16" X 2"	16-Gauge EG Staple
1/12" x 2"	16-Gauge Narrow Crown EG Staples
3/8" A11	Crown EG Hammertacker Staple

Plastic Caps



DESCRIPTION	QTY
1" Plastic Cap Nails	2,000
1" Plastic Cap Nails Bucket	3,000



1" Stinger NailPac (2000/box | 4/box per case | 96/pallet) (sold by the box) STINGER 136260



Stinger CN100 Cap Nail Gun STINGER 136250

Hand Drive Nails

Roofing Nail



Stainless Steel Options Available

HDG Box Nail

For applying roofing asphalt shingles, insulation board, and felt-to wood substrates. Also available in SS and Aluminum.

SIZE	GAUGE	HEAD	BOX WT.
3/4"	11	7/16"	50 lbs.
7/8"	11	7/16"	50 lbs.
1"	11	7/16"	50 lbs.
1-1/4"	11	7/16"	50 lbs.
1-1/2"	11	7/16"	50 lbs.
1-3/4"	11	7/16"	50 lbs.
2"	11	7/16"	50 lbs.
2-1/2"	11	7/16"	50 lbs.
3"	11	7/16"	50 lbs.
3-1/2"	11	7/16"	50 lbs.

Cedar Shake Nail



For cedar shake applications



STORMGUARD® Hand Drive Nails



STORMGUARD® Hot-Dipped Galvanized (HDG) Roofing, Siding, Decking or Trim Nails

Maze STORMGUARD® Nails are dipped twice in molten zinc for superior rust-protection. The first dip in the 1,000-degree molten metal puts on a thick layer of zinc - and the second dip Stormguard Nails, Double Dipped in Molten Zinc insures that there are no pinholes or imperfections in the coating.

STORMGUARD® Nails meet ASTM A-153 specifications for hot-dip galvanized hardware - and actually exceed the specs. in most cases.

Copper Hand Drive Nails



Ring Shank

SIZE	GAUGE	HEAD
1-3/4" (5D)	14	5/32"
2" (6D)	14	5/32"
2-1/2" (8D)	14	5/32"

Smooth Shank

SIZE	GAUGE	HEAD
1-3/4" (5D)	14	5/32"
2" (6D)	14	5/32"

PART NO.	DESCRIPTION
R102A	1-1/4" STORMGUARD® Shingles Nails (50lb. Box)
R103A	1-1/2" STORMGUARD® Shingles Nails (50lb. Box)
R105A	2" STORMGUARD® Shingles Nails (50lb. Box)
R107A	2-1/2" STORMGUARD® Shingles Nails (50lb. Box)
R159A	3" STORMGUARD® Shingles Nails (50lb. Box)
R1591A	3-1/2" STORMGUARD® Shingles Nails (50lb. Box)
R1593A	4-1/2" STORMGUARD® Ring-Shank Nails (50lb. Box)
T447A	8D 2-1/2" STORMGUARD® Double HDG Ring-Shank Nails (50lb. Box)
T4491A	16D 3-1/2" STORMGUARD® Double HDG Ring-Shank Nails (50lb. Box)

PART NO.	DESCRIPTION
CB 3R-CU114	1-1/4" Copper Ring Shank Hand Drive Roofing Nail (50lb. Box)
CB 3R-CU112	1-1/2" Copper Ring Shank Hand Drive Roofing Nail (50lb. Box)
CB 3R-CU134	1-3/4" Copper Ring Shank Hand Drive Roofing Nail (50lb. Box)
CB 3R-CU200	2" Copper Ring Shank Hand Drive Roofing Nail (50lb. Box)
CB 3R-CU212	2-1/2" Copper Ring Shank Hand Drive Roofing Nail (50lb. Box)
CB 3R-CU300	3" Copper Ring Shank Hand Drive Roofing Nail (50lb. Box)
CB 3J-CU114	1-1/4" Copper Smooth Shank Hand Drive Roofing Nail (50lb. Box)
CB 3J-CU112	1-1/2" Copper Smooth Shank Hand Drive Roofing Nail (50lb. Box)
CB 3J-CU134	1-3/4" Copper Smooth Shank Hand Drive Roofing Nail (50lb. Box)
CB 3J-CU200	2" Copper Smooth Shank Hand Drive Roofing Nail (50lb. Box)
CB 3J-CU212	2-1/2" Copper Smooth Shank Hand Drive Roofing Nail (50lb. Box)
CB 3J-CU300	3" Copper Hand Smooth Shank Drive Roofing Nail (50lb. Box)

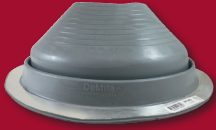

Dektite® Pipe Flashings



Long life, flexible, weather proof, gray EPDM rubber

- Does not crack or break
- Less building maintenance

Flexible, corrosive resistant, aluminum base

- Conforms to several panel profiles
- Fewer leaks

Pipe diameter markings

- Can be custom sized on the job site
- Tighter fit around pipe, fewer leaks



PART NO.	SIZE	DESCRIPTION	BASE TYPE
4001910	Mini Dektite®	MINI DEKTITE™ Pipe Flashing	Round
4003910	#1 Dektite®	Dektite® Pipe Flashing Gray	Round
4004910	#2 Dektite®	Dektite® Pipe Flashing Gray	Round
4009910	#3 Dektite®	Dektite® Pipe Flashing Gray	Round
4011910	#4 Dektite®	Dektite® Pipe Flashing Gray	Round
4016910	#5 Dektite®	Dektite® Pipe Flashing Gray	Round
4018910	#6 Dektite®	Dektite® Pipe Flashing Gray	Round
4020910	#7 Dektite®	Dektite® Pipe Flashing Gray	Round
4025910	#8 Dektite®	Dektite® Pipe Flashing Gray	Round
4028910	#9 Dektite®	Dektite® Pipe Flashing Gray	Round
4035910	#3 Silicone Dektite®	Dektite® Pipe Flashing Red	Round
4036910	#5 Silicone Dektite®	Dektite® Pipe Flashing Red	Round
4038910	#8 Silicone Dektite®	Dektite® Pipe Flashing Red	Round
4039910	#9 Silicone Dektite®	Dektite® Pipe Flashing Red	Round
4029910	801 Retrofit Dektite®	Dektite® Pipe Flashing Retrofit	Round
4030910	802 Retrofit Dektite®	Dektite® Pipe Flashing Retrofit	Round
4031910	803 Retrofit Dektite®	Dektite® Pipe Flashing Retrofit	Round

COLORADO

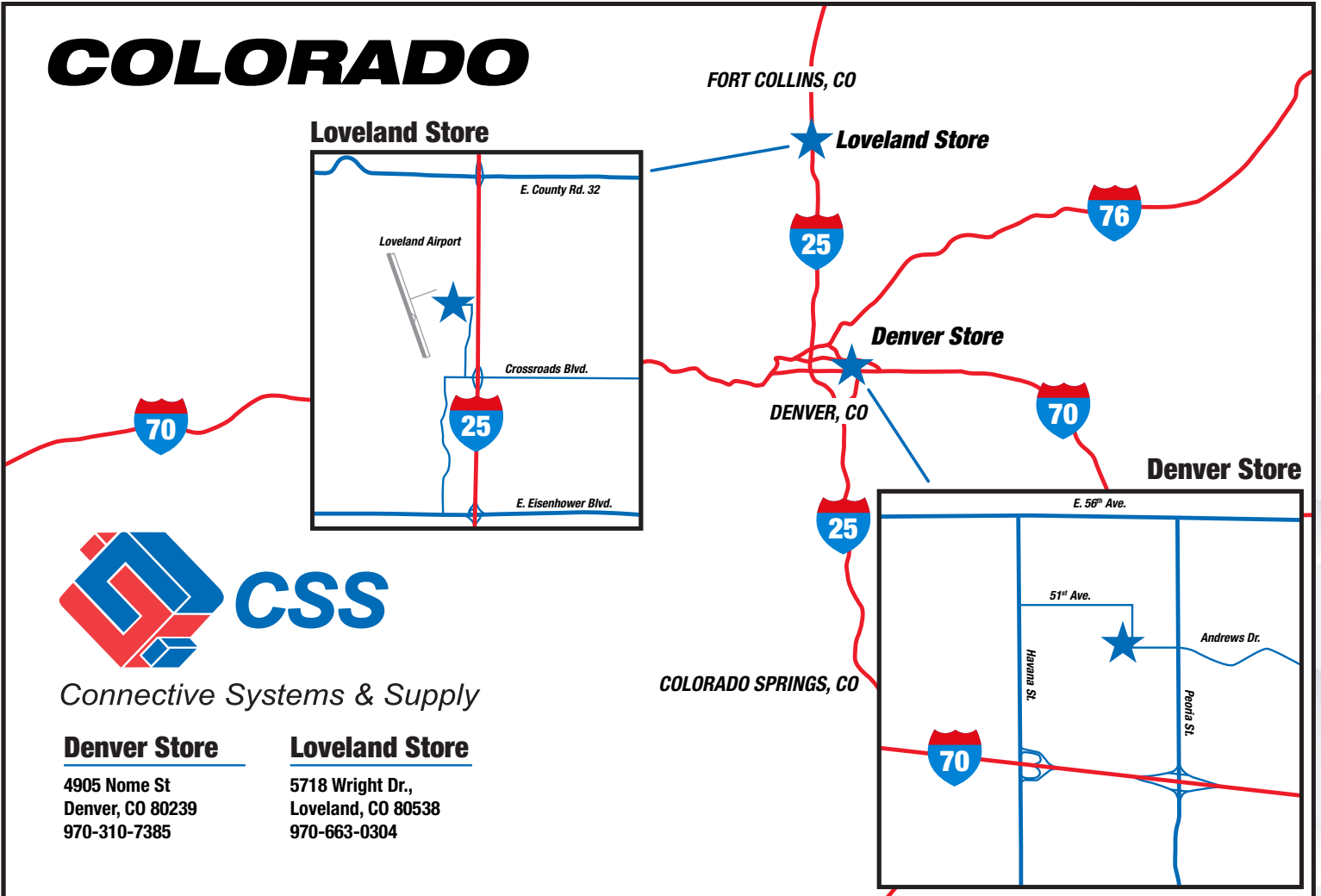

Connective Systems & Supply

Denver Store

4905 Nome St
Denver, CO 80239
970-310-7385

Loveland Store

5718 Wright Dr.,
Loveland, CO 80538
970-663-0304